

PCBRM15 & PCBRM System 5.2

Users Manual #4005.00.906



Through-Hole Selective Soldering



**AIR-VAC ENGINEERING COMPANY, INC.
INSTALLATION AND TRAINING**

Customer:		Date:	
Address:		Machine Type:	
		Serial Number:	
Contacts:			
	Phone:		E-mail/Fax:
	Phone:		E-mail/Fax:
	Phone:		E-mail/Fax:
This is to certify that the Air-Vac Representative _____ has installed the above machine and that all items have been received or are noted below. The machine is in good working order, and initial training was provided.			
Customer Signature/Date:			
Air-Vac Representative Signature/Date:			

Issues:

Items Missing:

Please fax this completed document to:
Air-Vac Engineering (203) 888-1145

Table of Contents

Part Number 4005.00.906
Rev 10.00
September 2025

Chapter 1: Introduction & General Overview

Chapter 2: Requirements & Machine Overview

Chapter 3: Set Up & Installation

Chapter 4: Processes & Applications

Chapter 5: Maintenance & Parts

Chapter 6: Troubleshooting

Chapter 7: Schematics

1: Introduction/Overview

- 1 Introduction/Overview3**
- 1.0 Welcome3**
- 1.1 PCBRM15 and PCBRM System 5.2 Overview3**
- 1.2 Contacts & Support3**
- 1.3 Warranty4**
- 1.4 Material Check List - PCBRM155**
- 1.5 Material Check List - PCBRM System 5.26**
- 1.6 Unpacking - PCBRM157**
- 1.7 Unpacking - PCBRM System 5.28**

1 Introduction/Overview

1.0 Welcome

Please read this User's Guide carefully before initial set-up of the PCBRM15 or PCBRM System 5.2 to insure the optimal start-up and maintenance of the equipment. This User's Guide has been compiled in accordance with ISO 9000 and the EC machine guideline regulations. It contains all information and instructions that are necessary for safe and trouble-free operation of the PCBRM15 and PCBRM System 5.2. Considerable time has been spent in an attempt to provide in-depth instructions in regards to the unpacking, installation, verification, operation and maintenance of these systems.

1.1 PCBRM15 and PCBRM System 5.2 Overview

The PCBRM15 and PCBRM System 5.2 machines provide lead-free selective soldering and rework of through-hole components and thermally challenging assemblies. The PCBRM System 5.2 adds a 6500 watt preheater.

1.2 Contacts & Support

Air-Vac is always willing to assist our customers with any technical or operating questions. If you have any questions on machine parameters, correct nozzle requirements, options, procedures or maintenance, please do not hesitate to call.

Air-Vac Engineering Company, Inc.
30 Progress Avenue, Seymour, CT 06483
Tel: 203-888-9900 - Fax: 203-888-1145
<http://www.air-vac-eng.com/>

General Sales, Tooling Information and Technical Support: airvac@air-vac-eng.com

1.3 Warranty

Air-Vac Engineering Company warrants its equipment for a period of one (1) year from date of shipment on all parts, materials and labor costs required to repair the system except for component parts that are considered "wear and tear" items which are warranted for ninety (90) days. These include, but are not limited to, heaters, belts, lights, vacuum cups and tubing.

Air-Vac agrees to repair or replace any or all such equipment that may prove to be defective within the warranty period, without expense, excluding shipping to the owner. This warranty shall not apply to any products that have been repaired or altered except by Air-Vac Engineering.

Services under warranty shall not affect an extension of the warranty period, nor will a new warranty period be granted for the parts, which were replaced/repared. The title of the replaced parts will automatically pass to Air-Vac.

Air-Vac reserves the right to reject replacement under this warranty where, in the sole opinion of Air-Vac, the defect is due to obvious misuse and/or improper maintenance of the module or any part thereof.

The express and/or implied warranty of Air-Vac is limited to the replacement and/or repair of any item defective in material and/or workmanship. Other damages, if any, direct or consequential are expressly excluded from this warranty.

Air-Vac shall be liable under this warranty only if 1) Air-Vac receives notice during the appropriate warranty period (90 days or 1 year as applicable); 2) The products are operated in accordance with the supplied documentation; and 3) Such products are, to Air-Vac's satisfaction, determined to be defective.

When contacting Air-Vac for warranty inquiries, please provide the following information:

- Order number which the parts were shipped
- Model and serial number of the product
- Reason for warranty

Products cannot be returned to Air-Vac without authorization – please call for an RMA #.

1.4 Material Check List - PCBRM15

The following 'Machine Section' is a checklist of items shipped with all PCBRM15 units.

MACHINE TOOL KIT - 12050

SERIAL NUMBER#

DESCRIPTION	QUANTITY	PART NUMBER	CHECK <input type="checkbox"/>
Sleeve Baffle	1	2004.01.102	
Extractor Tool	1	EX-2	
Set of fuses (packed in small plastic case):	1		
- 15 amp	2	9002.04.043	
- 1/2 amp	2	9002.04.038	
- 3/4 amp	2	9002.04.035	
- 3/10 amp	2	9002.04.040	
5/32" Tee Handle Allen Wrench	1	12050B	
1/4" Spintite Sprocket Wrench	1	12050A	
Graphite Anti-Sieze	1	AS15	
Bubble Level	1	12015	
Allen Wrench Set	1	12055	
3mm Allen Wrench	1	12050L	

MACHINE ACCESSORIES

DESCRIPTION	QUANTITY	PART NUMBER	CHECK <input type="checkbox"/>
Footswitch	1	12870	
Bailer	1	SL5	
Pot Cover	1	2004.01.108	
Manual	1	2004.00.900	
Ladel	1	9008.99.315	
Spatula	1	9008.99.314	
Gloves (pair)	1	12050M	

SPARE PARTS

DESCRIPTION	QUANTITY	PART NUMBER	CHECK <input type="checkbox"/>
Sleeve Baffle	1	2004.01.102	
Pump Assembly	1	2004.01.040	
Drive Belt (Hi Temp)	1	12467	
Pump Bearings (set of 2)	1	9001.09.020	
Thermocouple & Fitting (Process Temp.)	1	12801	
Thermocouple & Fitting (Over Temp.)	1	12802	
Temperature Controller (Process)	1	12860	
Cycle Controller Board	1	12862	
Solid State Relay, Pot	1	12865	

1.5 Material Check List - PCBRM System 5.2

The following 'Machine Section' is a checklist of items shipped with all PCBRM Systems.

MACHINE TOOL KIT - 12050

SERIAL NUMBER#

DESCRIPTION	QUANTITY	PART NUMBER	CHECK <input type="checkbox"/>
Sleeve Baffle	1	12011	
Extractor Tool	1	EX-2	
Set of fuses (packed in small plastic case):	1		
- 15 amp	2	9002.04.043	
- 1/2 amp	2	9002.04.038	
- 3/4 amp	2	9002.04.035	
- 3/10 amp	2	9002.04.040	
5/32" Tee Handle Allen Wrench	1	12050B	
1/4" Spintite Sprocket Wrench	1	12050A	
Graphite Anti-Sieze	1	AS15	
Bubble Level	1	12015	
Allen Wrench Set	1	12055	
3mm Allen Wrench	1	12050L	
Spatula	1	9008.99.314	

MACHINE ACCESSORIES

DESCRIPTION	QUANTITY	PART NUMBER	CHECK <input type="checkbox"/>
Footswitch	1	12870	
Bailer	1	SL5	
Pot Cover	1	12590	
Manual	1	3006.00.903	
Ladel	1	9008.99.315	
Gloves (pair)	1	12050M	

SPARE PARTS

DESCRIPTION	QUANTITY	PART NUMBER	CHECK <input type="checkbox"/>
Sleeve Baffle	1	12011	
Pump Assembly	1	12401	
Drive Belt (Hi Temp)	1	12467	
Pump Bearings (set of 2)	1	9001.09.020	
Thermocouple & Fitting (Process Temp.)	1	12801	
Temperature Controller (Process)	1	12802	
Cycle Controller Board	1	12862	
Solid State Relay, Pot	1	12865	

1.6 Unpacking - PCBRM15

Shipping Weight: - 170 lbs.

Shipping Dimensions (W x D x H): - 43" x 34" x 30"

IMPORTANT!!

(X) DO NOT LIFT OR PULL HERE AT POINTS INDICATED, DAMAGE TO SYSTEM MAY RESULT.

- Position module on a level surface which can provide adequate support for weight.
- Accessories are normally shipped in box with module. Please inspect carefully and check that all items have been shipped.
- Save shipping box for any future shipping.



1.7 Unpacking - PCBRM System 5.2

Shipping Weight: - 250 lbs.

Shipping Dimensions (W x D x H): - 67" x 35" x 52"

IMPORTANT!!

SUPPORT MUST BE PROVIDED IN CENTER. BASE PLATE WILL BEND. LIFT MACHINE WITH A FORK LIFT AS SHOWN.

**DO NOT LIFT OR PULL HERE.
DAMAGE TO SYSTEM MAY RESULT.**

- X** Position module on a level surface which can provide adequate support for weight.
- Accessories are normally shipped in box with module. Please inspect carefully and check that all items have been shipped.
- Save shipping box for any future shipping.

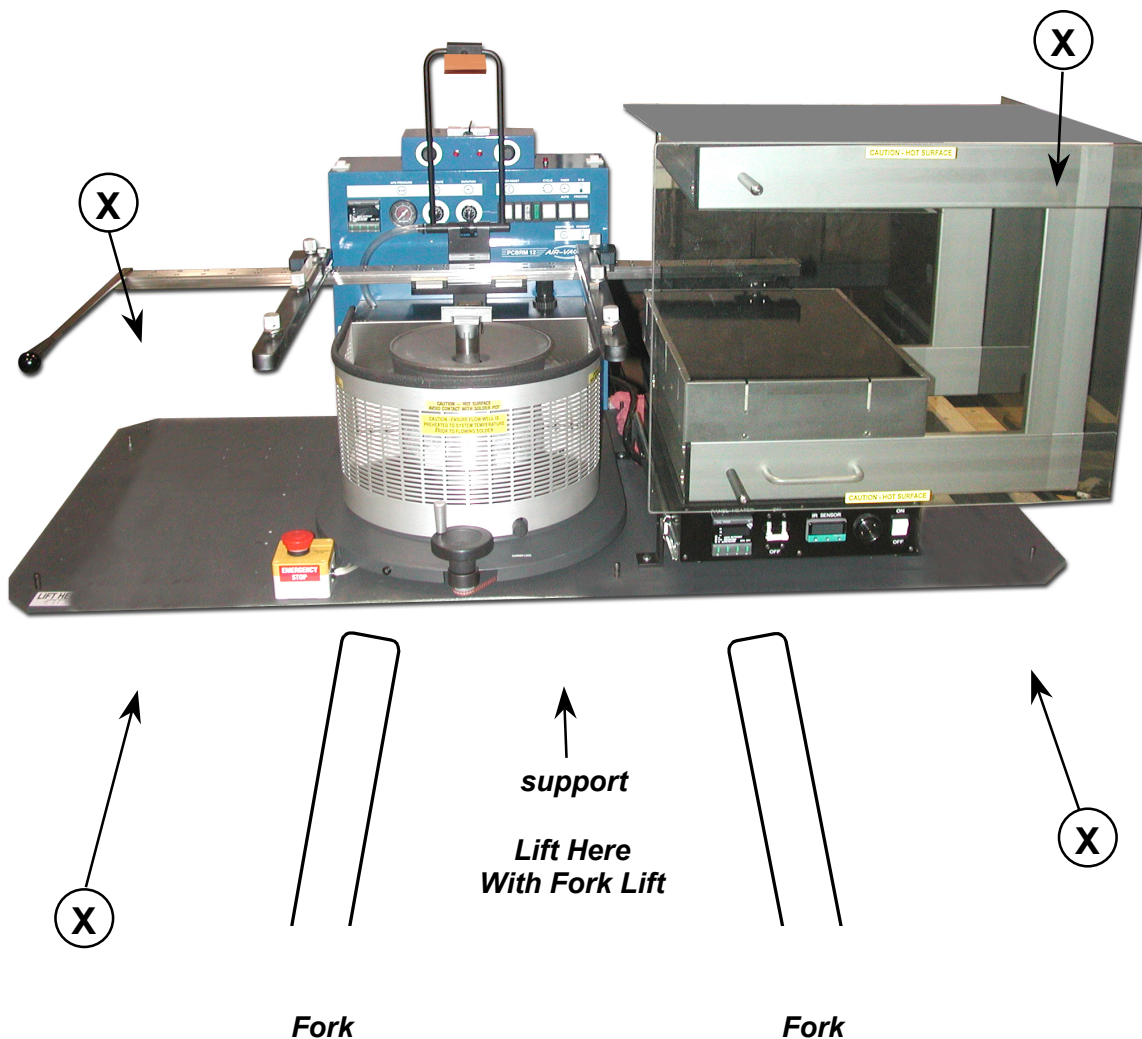

2: Requirements/Machine Overview

2	<i>Requirements/Machine Overview</i>	3
2.1	Facility Requirements - PCBRM15	3
2.2	Facility Requirements - PCBRM System 5.2	3
2.3	PCBRM15 - Module Overview	4
2.4	PCBRM15 and System 5.2 - Control Panel Overview	5
2.5	PCBRM15 - Carrier Overview	7
2.6	PCBRM System 5.2 – System Overview	8
2.7	PCBRM System 5.2 PCB Carrier Overview	11

2 Requirements/Machine Overview

2.1 Facility Requirements - PCBRM15

- Physical Dimensions: 32"W x 26"D x 26"H
- Maximum Board Size: 22"W x 21"D
- Weight: 125 lbs. (with solder), 90 lbs. (without solder)
- Electrical Requirements:
 - Machine (PCBRM15): 208/220VAC, 13 Amps, 50/60 Hz, Single Phase.
Plug = 15 Amp, 250VAC, Nema 6-15P.
 - Heater Box (optional): 110/120VAC, 4 Amps, 50/60 Hz, Single Phase.
(PCBRM15)
 - Machine (PCBRM15.Z): 208/220VAC, 13 Amps, 50/60Hz, Single Phase.
Plug = Continental Europe 16 Amp
 - Heater Box (optional): 208/220VAC, 2 Amps, 50/60Hz, Single Phase
(PCBRM15.Z)
- Compressed Air (optional): 40-80 psi, 2 scfm, clean, moisture-free air (intermittent),
1/8 NPT(M) fitting required.

2.2 Facility Requirements - PCBRM System 5.2

- Max Operating Dimensions: 76"W x 38"D x 28"H
- Weight: 230 lbs. (with solder), 195 lbs. (without solder)
- Electrical Requirements:
 - Machine (System 5.2): 208/220 Vac, 45 Amps-full load (overload protected to 55 Amps),
50/60 Hz, single phase, 6 awg 3 wire cord supplied.
 - Heater Box (optional): 120 Vac, 4 amps, 50/60 Hz, single phase.
(System 5.2)
 - Machine (System 5.2.Z): 208/220 Vac, 15 Amps-full load (overload protected to 20 Amps),
50/60 Hz, 3 phase, 2.5mm² x 5 wire cord provided.
 - Heater Box (standard): 220 Vac, integral with machine power
(System 5.2.Z)
- Compressed Air (optional): 40-80 psi, 2 scfm, clean, moisture-free air (intermittent),
1/8 NPT(M) fitting required.

Miscellaneous

- 35 lbs. of solder
- Level work area.
- Venting is recommended.

2.3 PCBRM15 - Module Overview

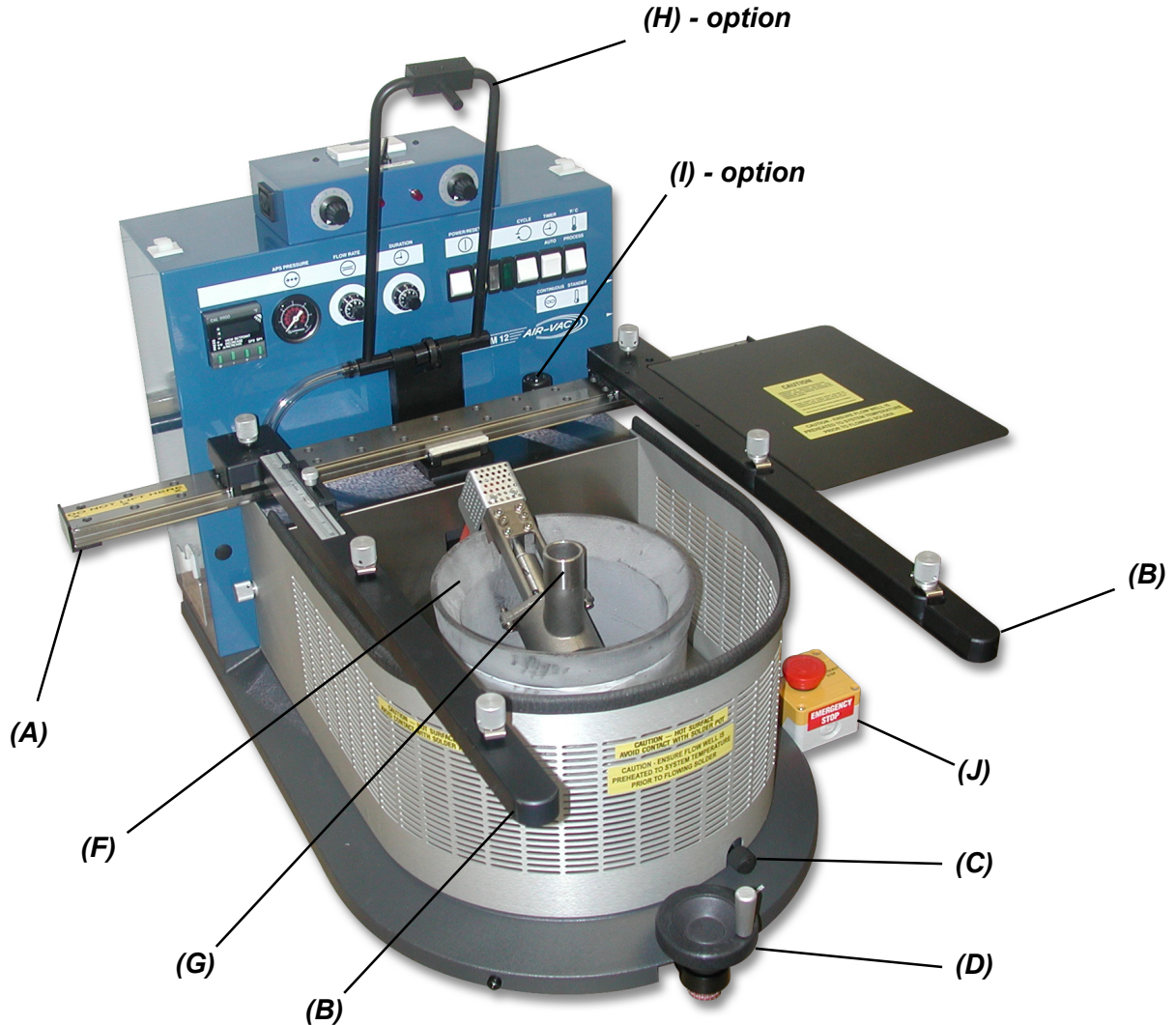

- (A) X-Axis Carrier Rail** - Cantilever carrier rail adjusts to hold PCB up to 22"W.
- (B) PCB Carrier Arms** - Carrier arms hold PCB up to 21" deep. PCB Stops with reference scale provides one time set-up of repetitive assemblies.
- (C) X-Axis Carrier Lock** - Once PCB is aligned over flow well, the carrier is locked in place.
- (D) Z-Axis Height Adjustment** - Adjusts height of PCB in relation to the flow well.
- (F) Solder Pot**
- (G) Solder Pump**
- (H) APS System**- Blows low pressure air through holes in PCB of removed component to clear them of solder.
- (I) APS System Air Regulator** - Sets air pressure.
- (J) Emergency Stop** - Shuts system down immediately if required.

2.4 PCBRM15 and System 5.2 - Control Panel Overview

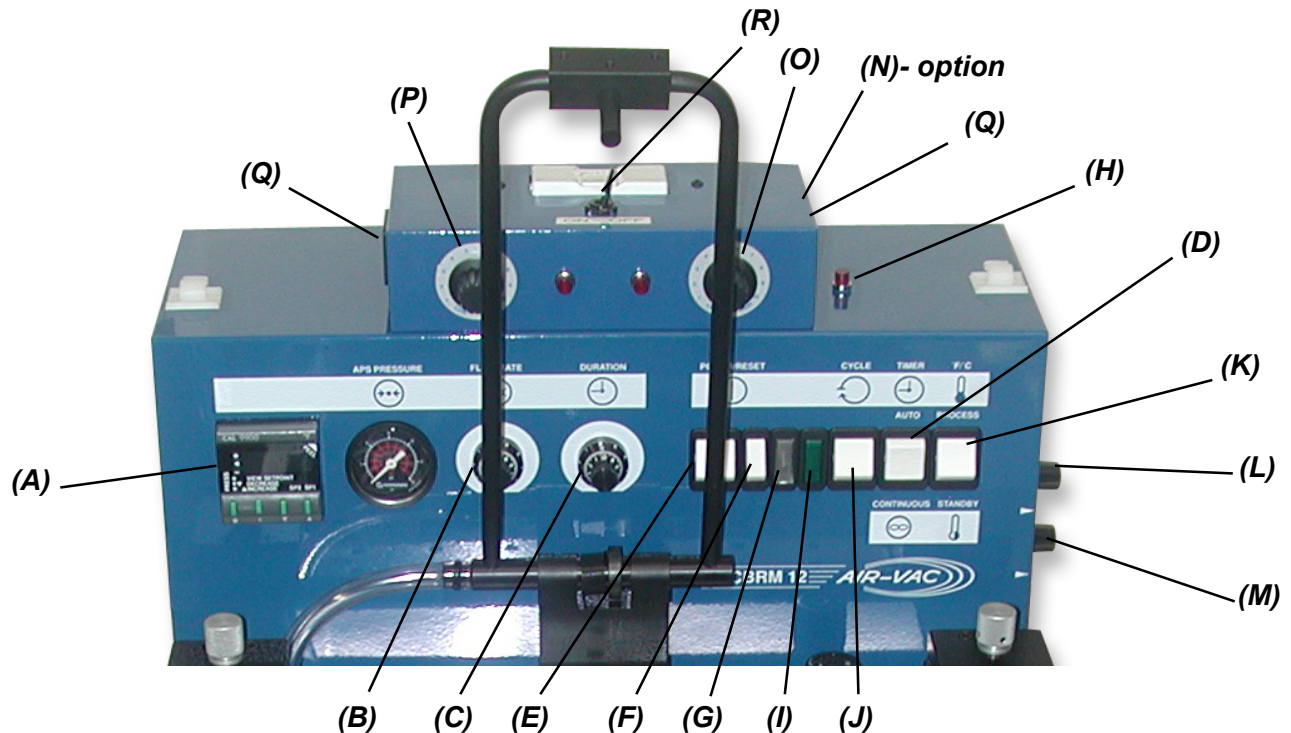

(A) Digital Temperature Controller - Microprocessor provides two programmable set points: Process Temperature and Standby/Interlock Temperature. Digital readout of actual temperature is accurate within +/-1% of full scale. (Thermocouple is located at bottom of solder pot).

(B) Solder Flow Rate Control – Process flow rate can be varied and controlled during the duration cycle. There are three Solder Flow Rate Controls: Ramp Up, Process, and Ramp Down. The Flow Rate Control adjusts the pumping speed of the solder to produce a level flowing wave through the Flow Well. Too low of speed will not pump the solder against the pcb contacting all the component leads. Too high a setting will cause solder to flood the board surface.

(C) Solder Duration Control – The length of the time solder flows in one cycle can be set. The process cycle can be started by either depressing the START ON the Footswitch or pressing the CYCLE Start-switch.

- **(D) Mode Switch - Automatic Mode** – With the Timer Switch in the Automatic Mode, specific timing logic is available up to 60 seconds and is adjusted and set by the Duration Control. The settings between 1 and 5 give the range used for most applications. If the cycle needs to be interrupted, pressing the STOP ON of the Footswitch will stop the cycle.
- **(D) Mode Switch - Continuous Mode** – With the Mode Switch in Continuous, the Duration Control Logic and Cycle Start Switch are now by-passed. Solder will flow until the STOP pedal is depressed. Solder flow will not resume until the STOP pedal is released. The Continuous Mode is operator controlled.

Note:

THE CENTER POSITION OF THE MODE SWITCH (D) IS “OFF”.

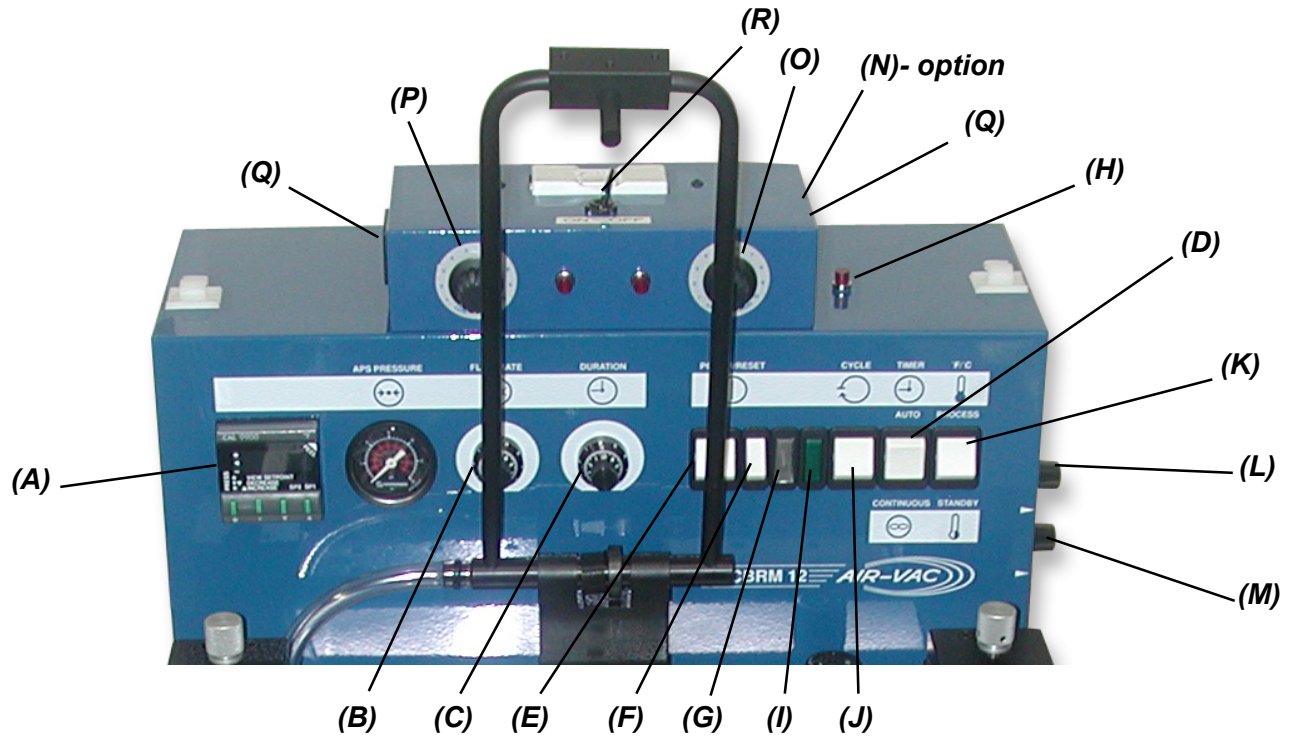

- (E) Main Power Switch** – ON/OFF provides electrical power to the systems.
- (F) Relatch Switch** – Resets Main Power after unit is turned off or Emergency stopped.
- (G) White Light** – Indicates Main Power is on.
- (H) Transformer Breakdown Light** – Indicates failure of transformer coil isolation.
- (I) Green Light** – Indicates solder is molten and the machine is ready to cycle.
- (J) Cycle Switch** – Activates the Cycle Duration with Mode Switch in Automatic Mode.
- (K) Temperature Controller** – Controls temperature of solder.
- (L) Ramp Up Flow Rate** - Adjusts motor start speed of the pump, either quickly or slowly. To increase ramp time, turn knob counter-clockwise. To decrease, turn clockwise.
- (M) Ramp Down Flow Rate** - Adjusts motor stop speed of the pump, either quickly or slowly. This can help to produce a better solder joint. To increase ramp time, turn the knob counter-clockwise, to decrease turn clockwise.

Note:

FLOW RATE INFLUENCES THE TOTAL DURATION/PROCESS CYCLE. RAMP DOWN FLOW RATE INFLUENCES THE TIME WHEN THE AIR IS ACTIVATED FOR THE AIR CLEANING SYSTEM (APS OPTION). FOR SOLDERING, SET RAMP DOWN TO "0". FOR DESOLDERING, SET TO "10".

- (N) Flow Well Heater Box (option)** – When external heaters are required for heating large flow wells.
- (O) Heater Control Right (high/low)** – Adjusts right flow well heater from low to high temp.
- (P) Heater Control Left (high/low)** – Adjusts left flow well heater from low to high temp.
- (Q) Left & Right Plugs** – Plug heater for flow wells here.
- (R) ON/OFF Switch**

2.5 PCBRM15 - Carrier Overview

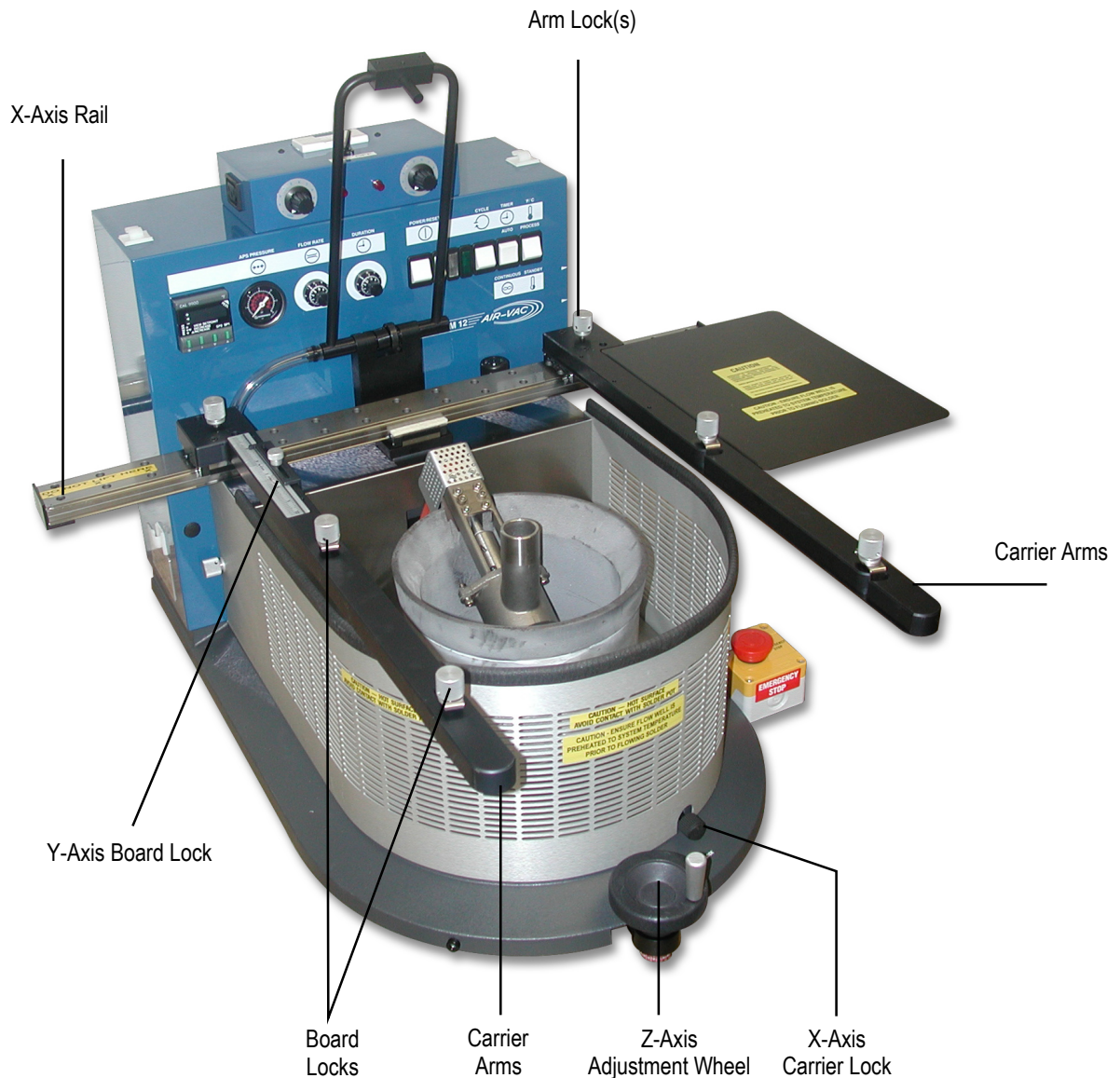

Carrier Arms: Hold board level to solder wave. Adjust to width of board.

X-Axis Carrier Lock: Locks carrier in place once board is aligned over flow well.

Board Locks: Locks board in carrier arms.

Y-Axis Board Lock: Sets y-axis position of board.

Z-Axis Adjustment: Adjusts height of carrier/board in relationship to the flow well.

X-Axis Lock (preheater): Sets x-axis position of carrier/board to flow well.

Arm Lock(s): Lock carrier arms on x-axis rail to hold PCB.

X-Axis Rail: Moves PCB left to right from loading PCB to flow well.

2.6 PCBRM System 5.2 – System Overview

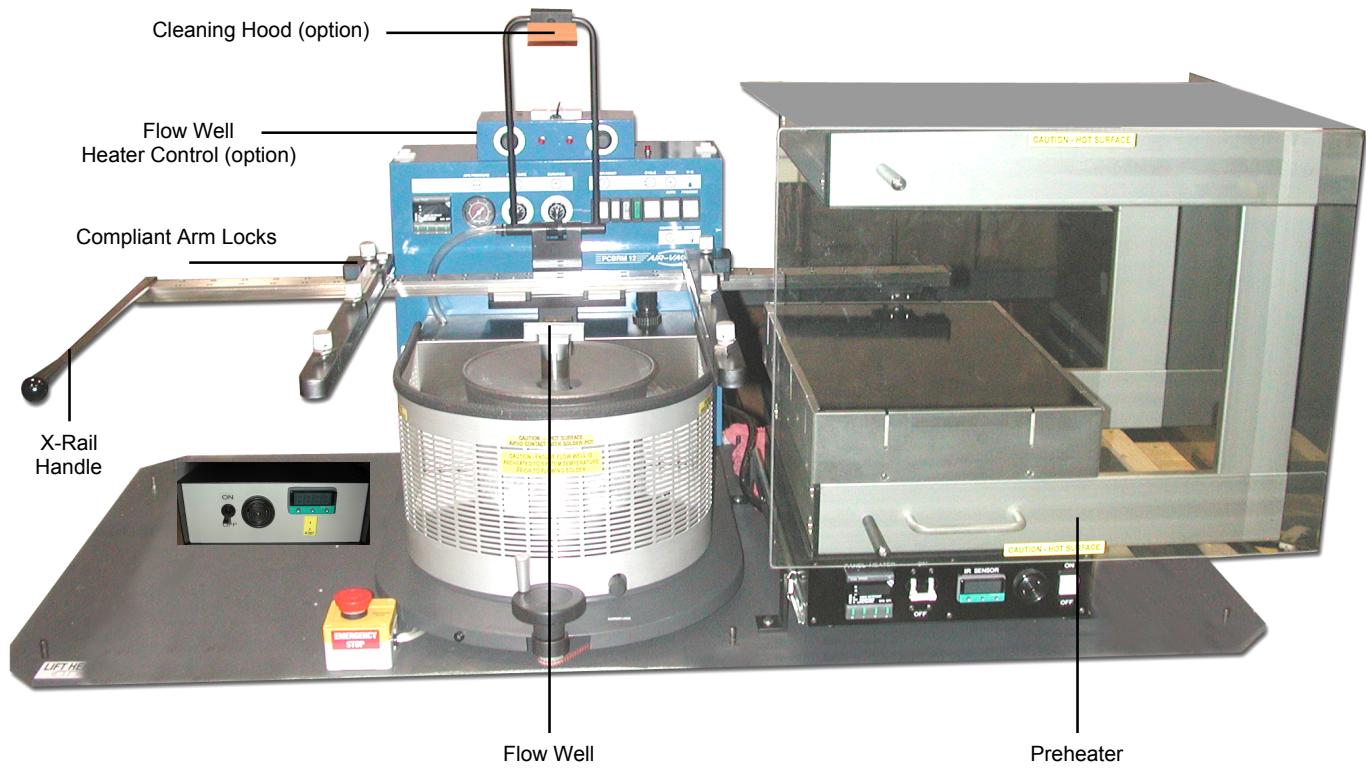

Z-Axis Positioning Knob



X-Axis Stop (preheater)

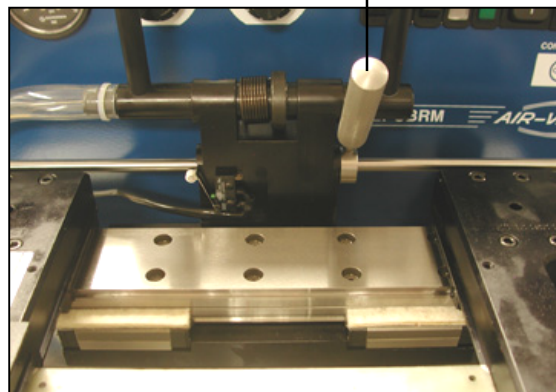

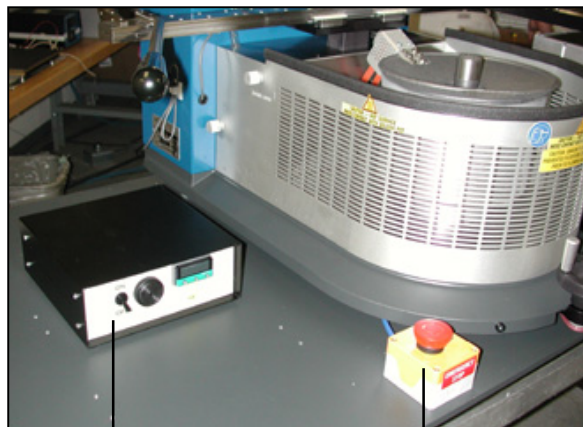
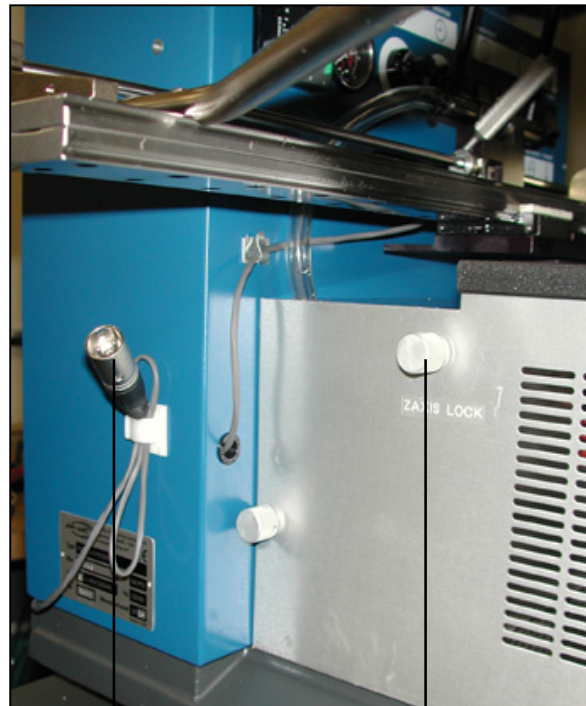
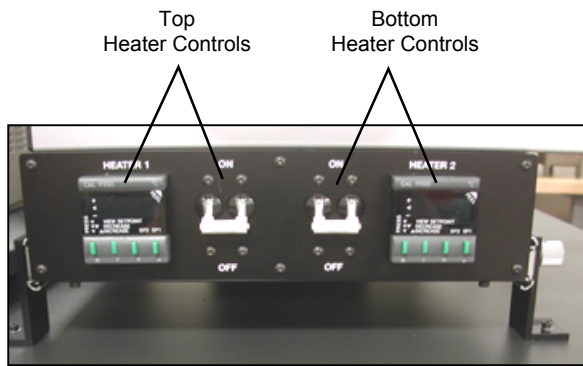

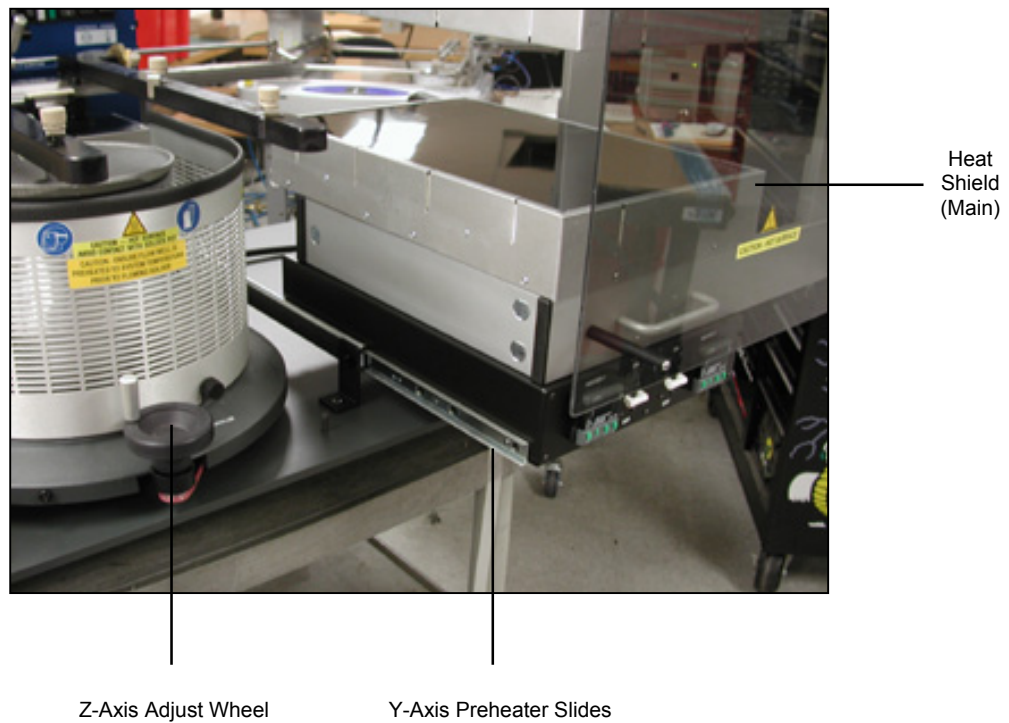

2.7 PCBRM System 5.2 PCB Carrier Overview

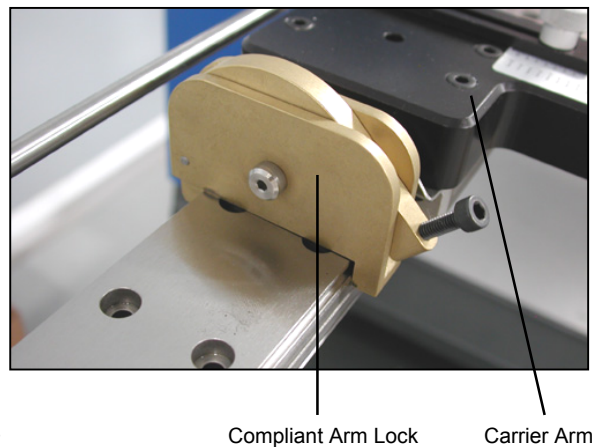
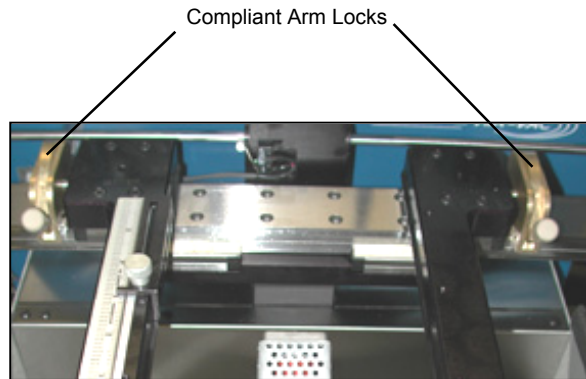
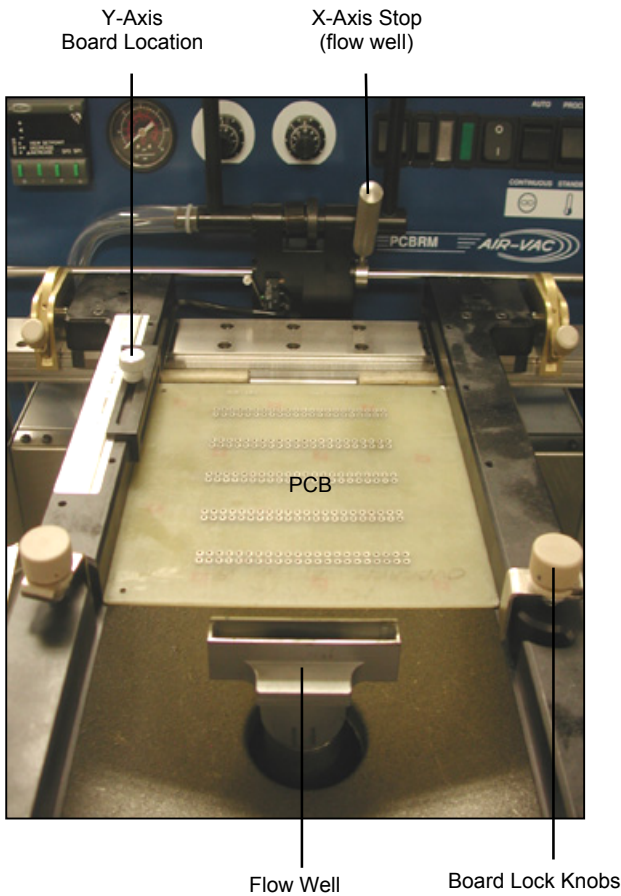
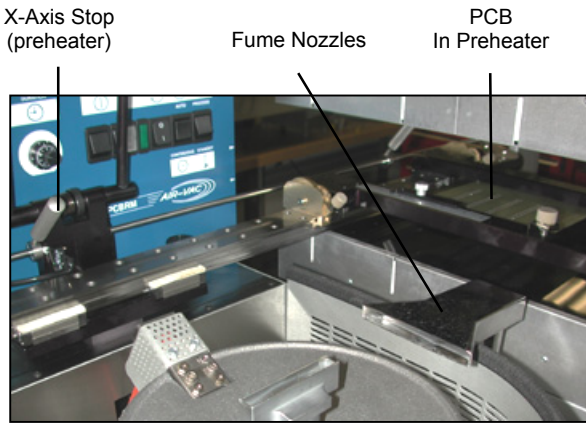
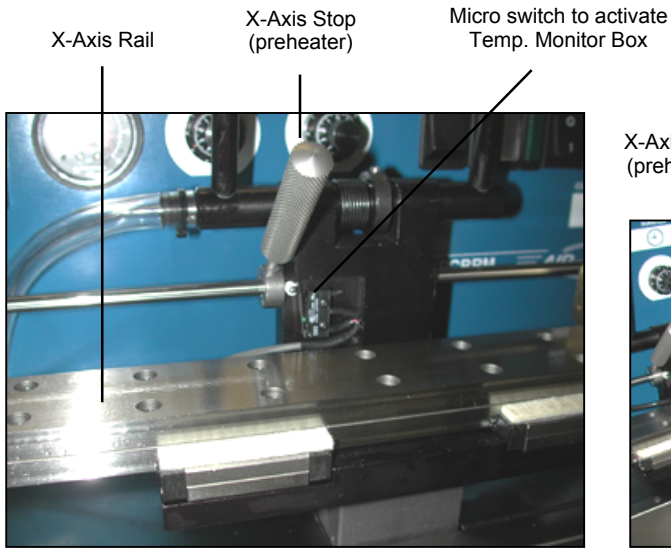

3: Set Up & Installation

3	<i>Set Up & Installation</i>	3
3.1	Leveling Module	3
3.2	PCBRM15 – Carrier Arms Installation	4
3.3	PCBRM System 5.2 - Carrier Arms Installation	7
3.4	PCBRM System 5.2 – X Axis Stops, Set Up, Function	8
3.5	PCBRM System 5.2 – Z Axis Stop, Set Up, Function	9
3.6	PCBRM System 5.2 - Preheater Safety Stop	10
3.7	<u>Optional</u> Fume Extraction Manifold Assembly Installation	11

3 Set Up & Installation

3.1 Leveling Module

CAUTION:

OPERATION OF THIS MODULE INVOLVES PUMPING OF MOLTEN SOLDER. ALL NORMAL SAFETY PRACTICES SHOULD BE OBSERVED WITH SPECIAL ATTENTION TO THE FOLLOWING:

SAFETY GLASSES SHOULD BE WORN AT ALL TIMES.

DO NOT MOVE MODULE WHILE SOLDER IS MOLTEN.

DISCONNECT POWER BEFORE SERVICING MODULES.

CAUTION:

LEVELING OF MODULE SHOULD NOT BE ATTEMPTED WITH MOLTEN SOLDER IN THE POT.

Note:

LEVELING IS CRITICAL TO PROVIDE CORRECT SOLDER FLOW.

- Level machine on table.
- Place the level (supplied with tool kit) on **Pump Housing (A)**. Level machine (front to back and side to side) by adjusting the Leveling Legs.
- After leveling is completed, lock legs with jam nuts.

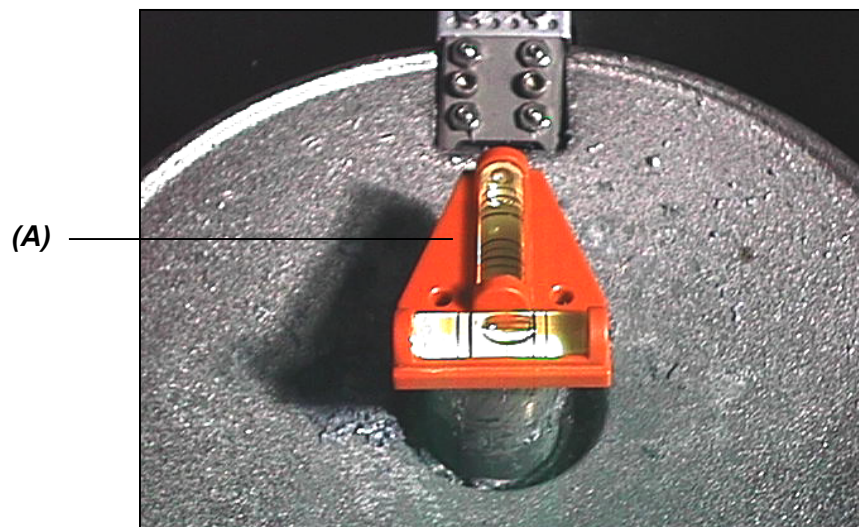

3.2 PCBRM15 – Carrier Arms Installation

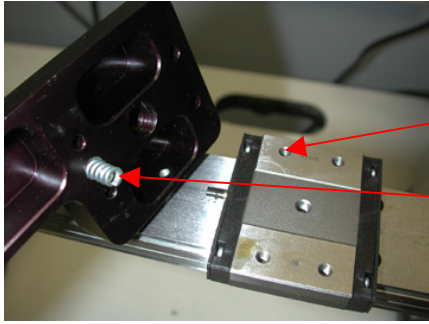

- Install right and left carrier arms to the bearing block using the M4 screws supplied.
- When installing the arms, please note that the spring must be installed as shown.

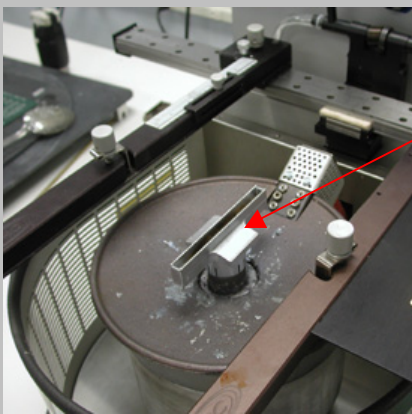

1. Start with a flow well installed on the solder pump.

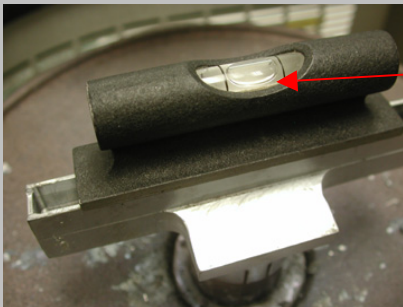

2. Place a level on the flow well and note level of the well.



3. Place the board to be used in the process in to the carrier arms. Align the site to be processed on the board over the flow well and lock in place.

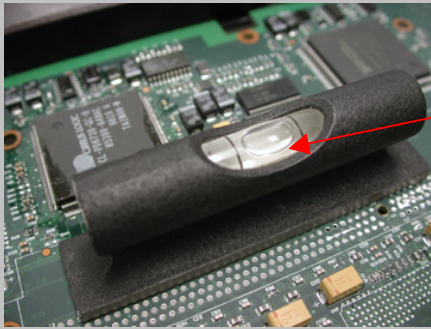

4. The board now will need to be leveled to match the flow well. (step 2)

NOTE: The adjustment will be in the Y-axis only not the X-axis

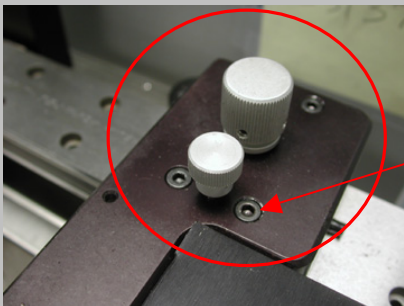
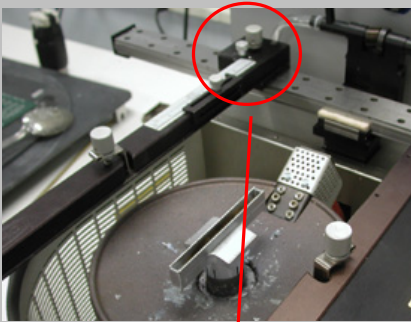

5. To adjust the board to match the flow well, loosen the two front screws only on each arm two turns.

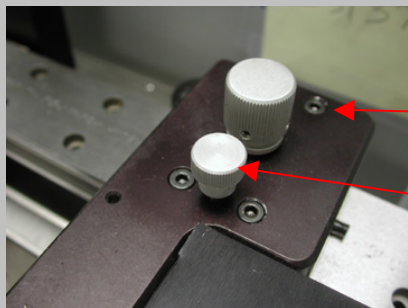

6. Loosen the rear two screws of each arm _ turn.
7. Turn the adjustment screw clockwise on both arms equally an 1/8 of a turn at a time until the level is at the desired place.
8. Once level is achieved, bring the rear two screws to bare only. Make a final adjustment as required and bring the front screws to bare. Now snug up all the screws – Do Not Over tighten.

3.3 PCBRM System 5.2 - Carrier Arms Installation

- Loosen lock knob so compliant (carrier) arm lock assembly can straddle the x-axis rail.
- Place compliant arm lock assembly in place, as shown.
- Use mounting screws to mount carrier arm to bearing block.

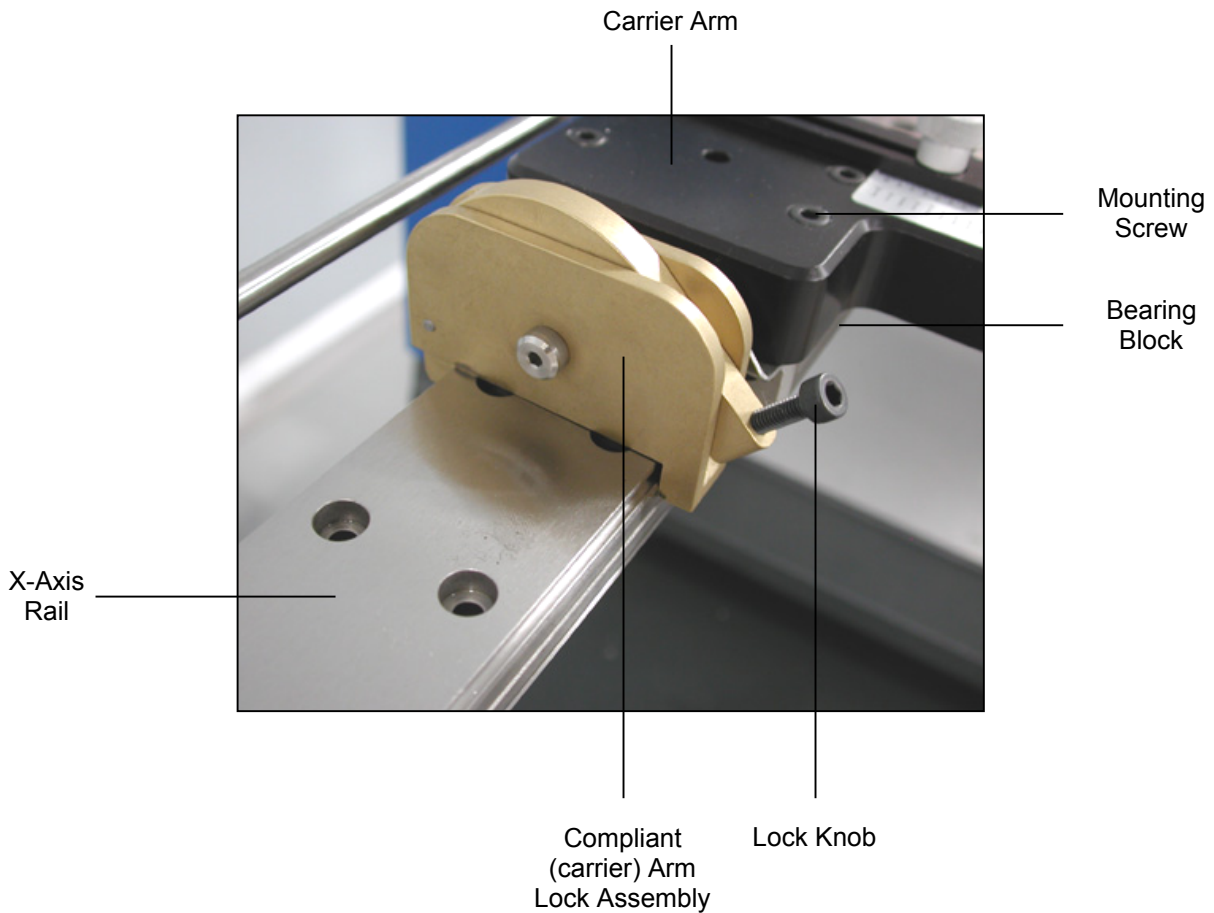

3.4 PCBRM System 5.2 – X Axis Stops, Set Up, Function

- Locate PCB in carrier arms and lock arms in place using compliant arm lock knobs.
- Locate PCB in the y-axis and set stop.
- Lock PCB in arms using board lock knobs.

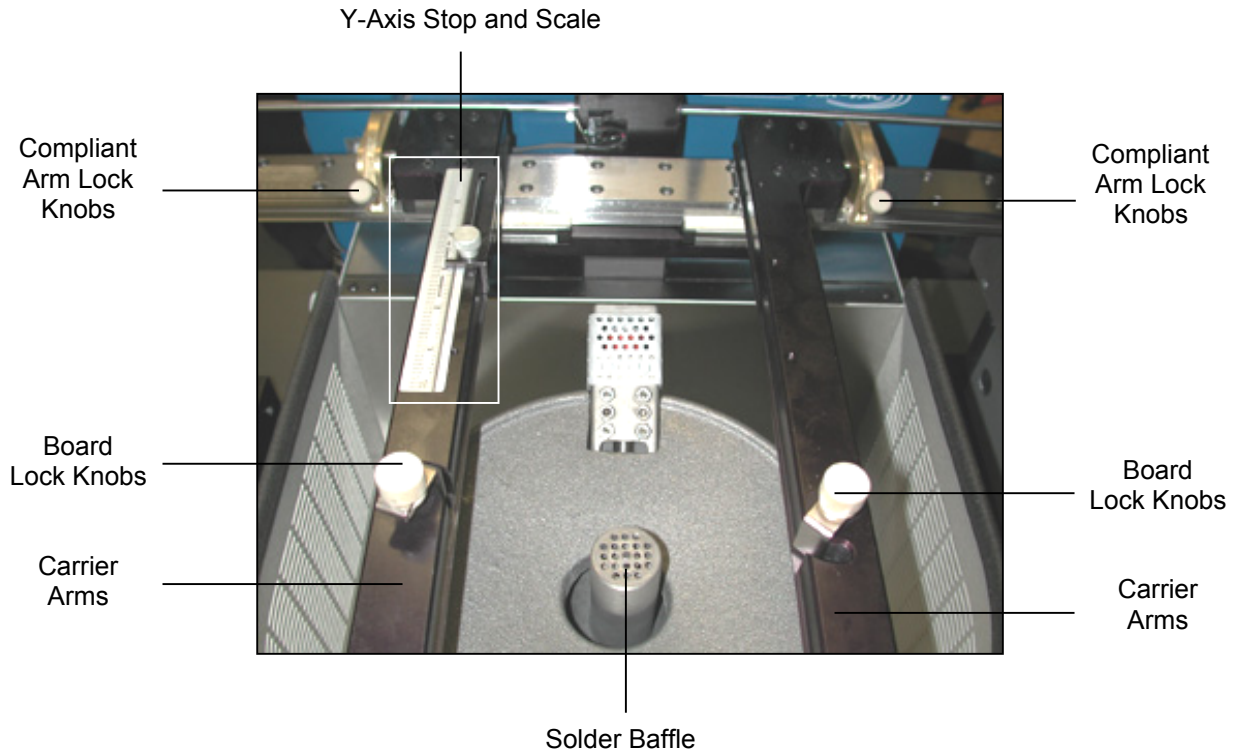

- Set x-axis stop (preheater) once PCB has been located in the preheater.

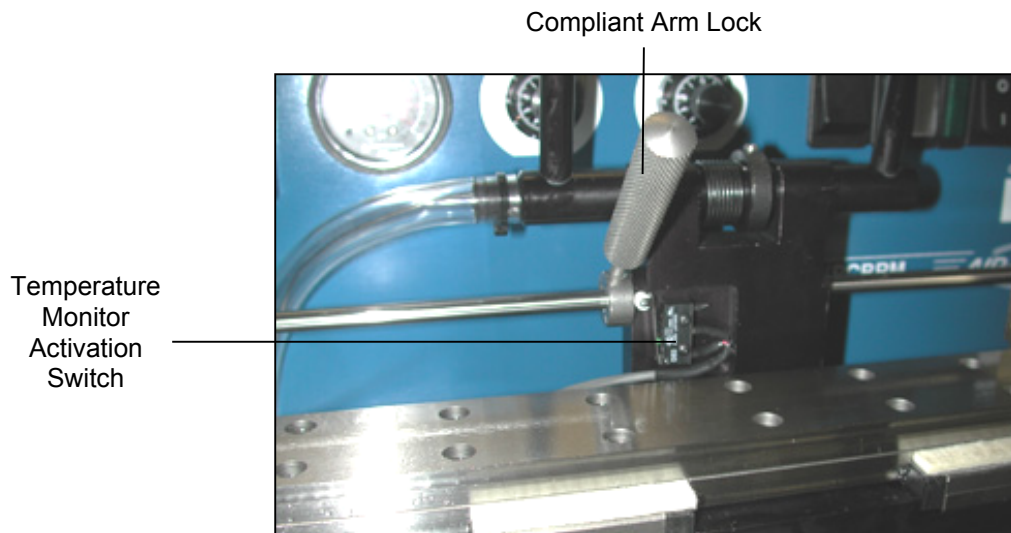

3.5 PCBRM System 5.2 – Z Axis Stop, Set Up, Function

- The z-axis lock presets a repeatable stop in the Z-Axis for board solder location.

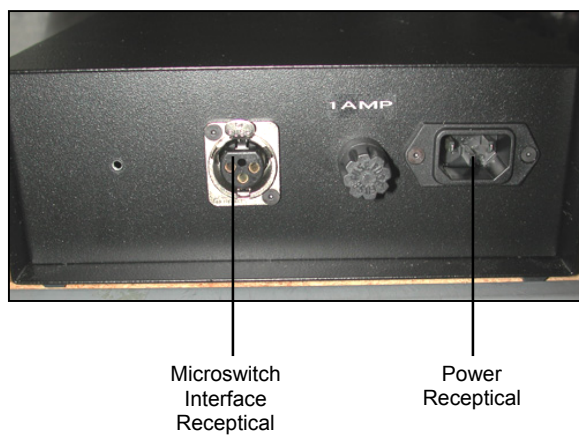
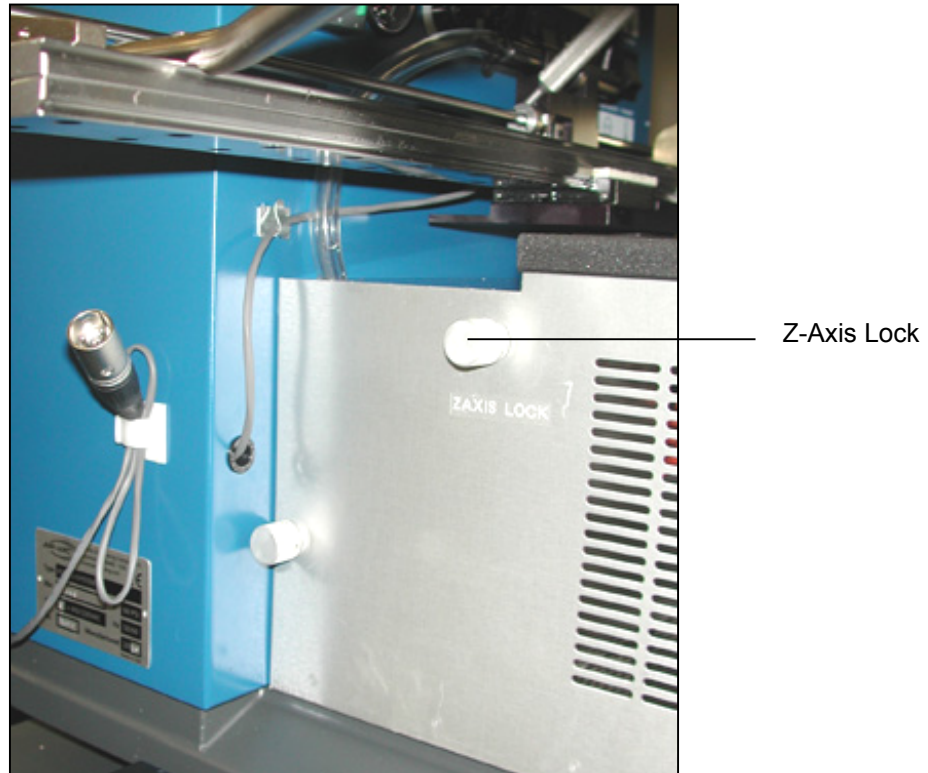

3.6 PCBRM System 5.2 - Preheater Safety Stop

- Safety Stop is removed for shipping. Install once machine is set up. Slide preheater forward and install screw and washer into hole. Secure with lock washer and nut. Place protective tube over the end of exposed screw.

CAUTION:

FAILURE TO INSTALL THIS STOP COULD RESULT IN DAMAGE TO SYSTEM.



Y-Axis Preheater Lock Knob

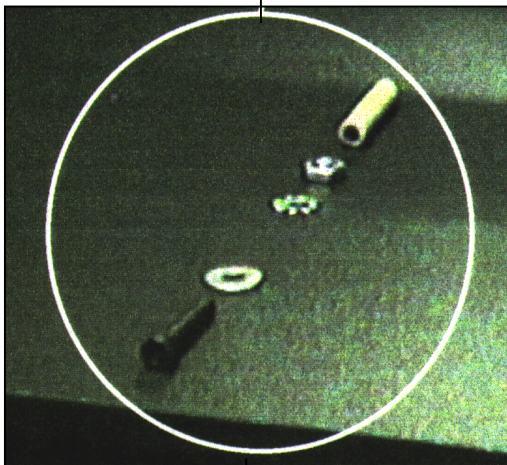

Safety Stop



Preheater Slides

3.7 Optional Fume Extraction Manifold Assembly Installation

- The Optional Fume Extraction Manifold (for PCBRM15 or PCBRM System 5.2) consists of an **Overhead Arm (A)**, **two Exhaust Nozzles (B)** and **2" Diameter Hoses** which can be attached to an in-house or separate filtration system.

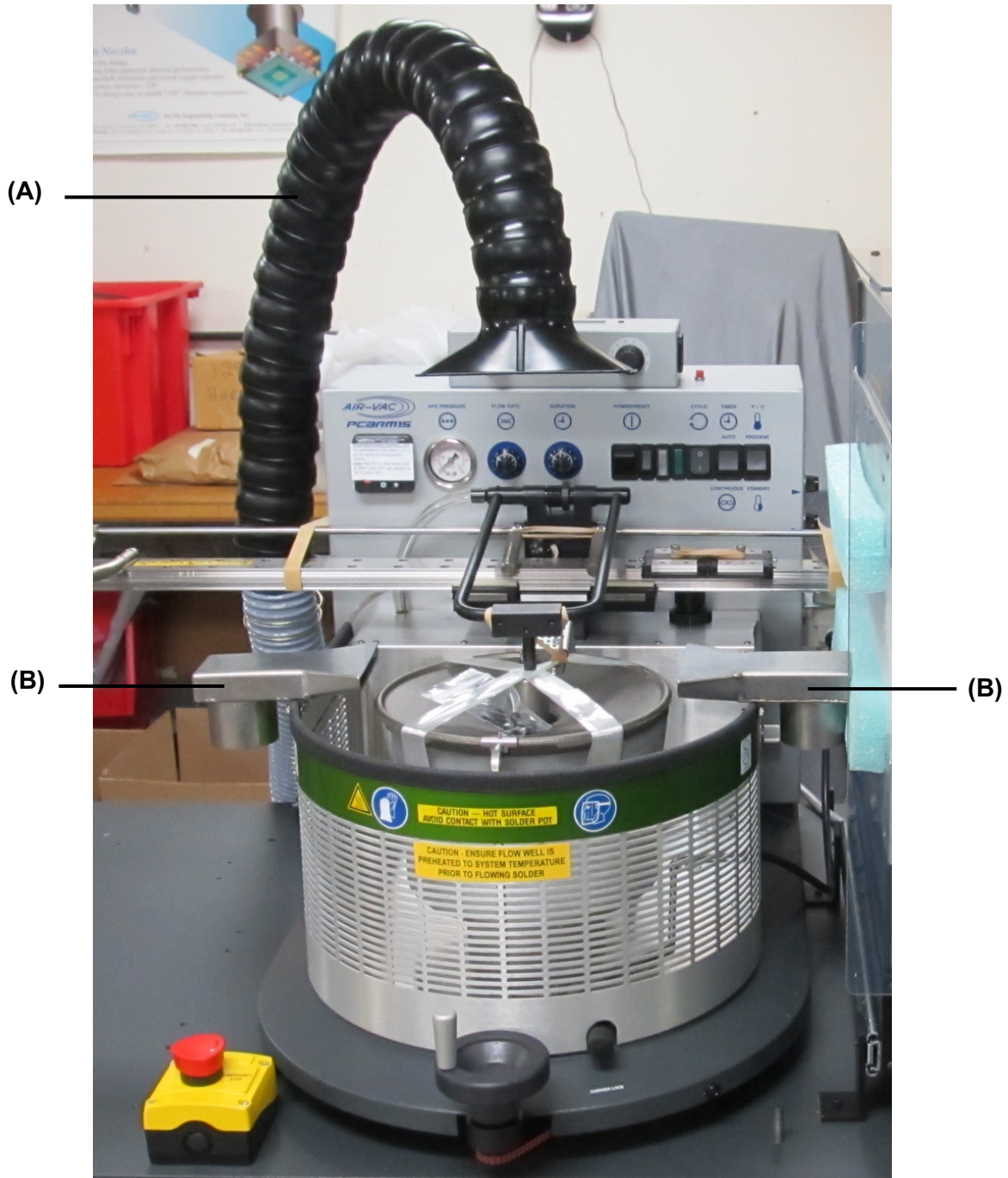

- Overhead Arm mounts to **bracket (C)**, which mounts to the left side of the PCBRM (hardware included).

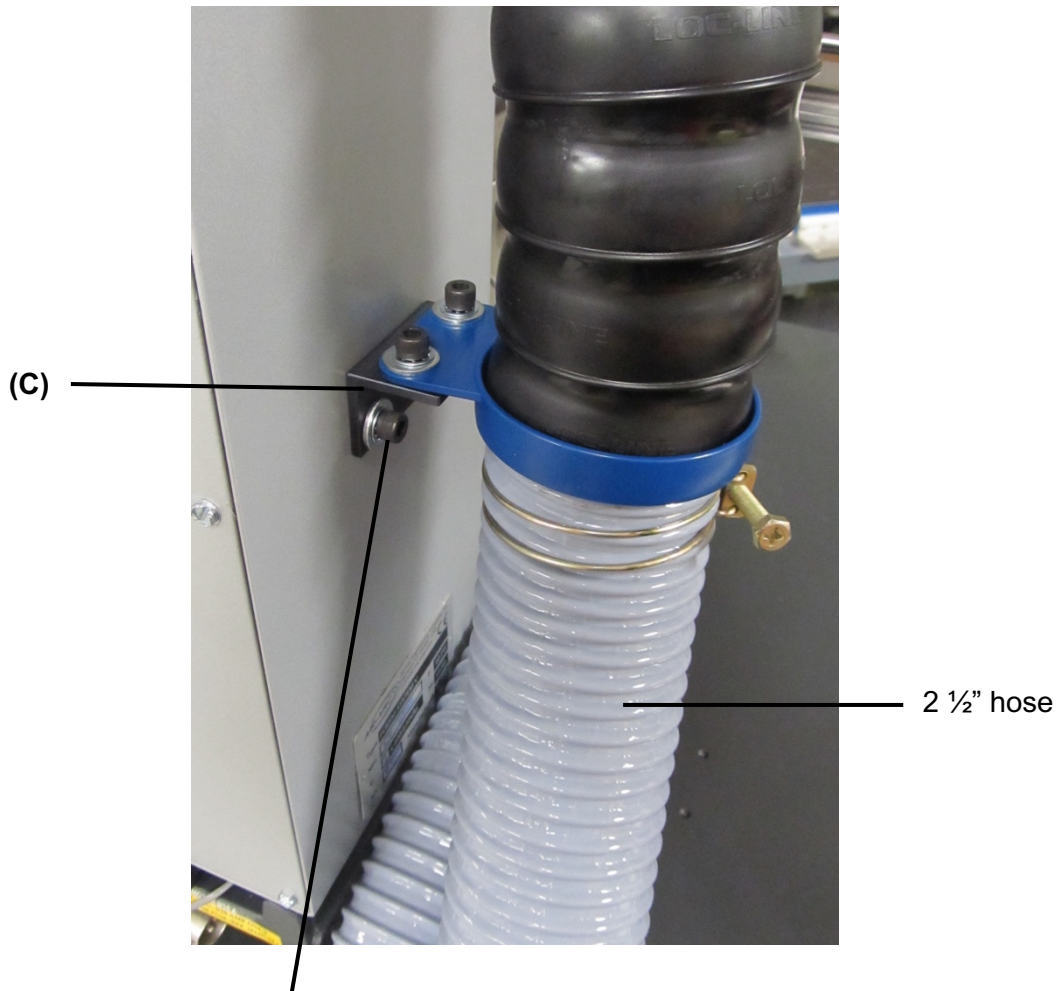

(1/4-20 x 3/8 screws and washers included)

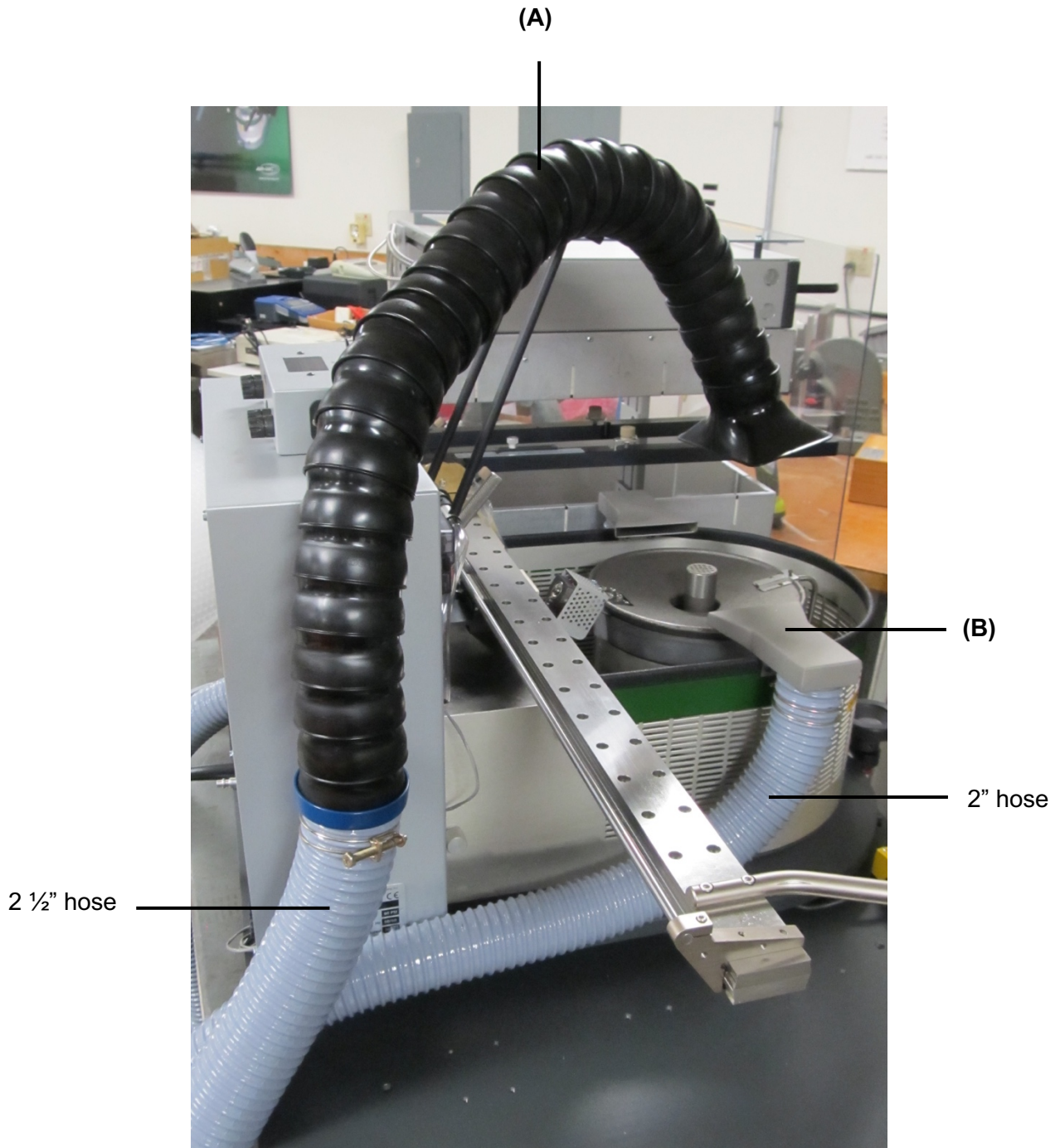

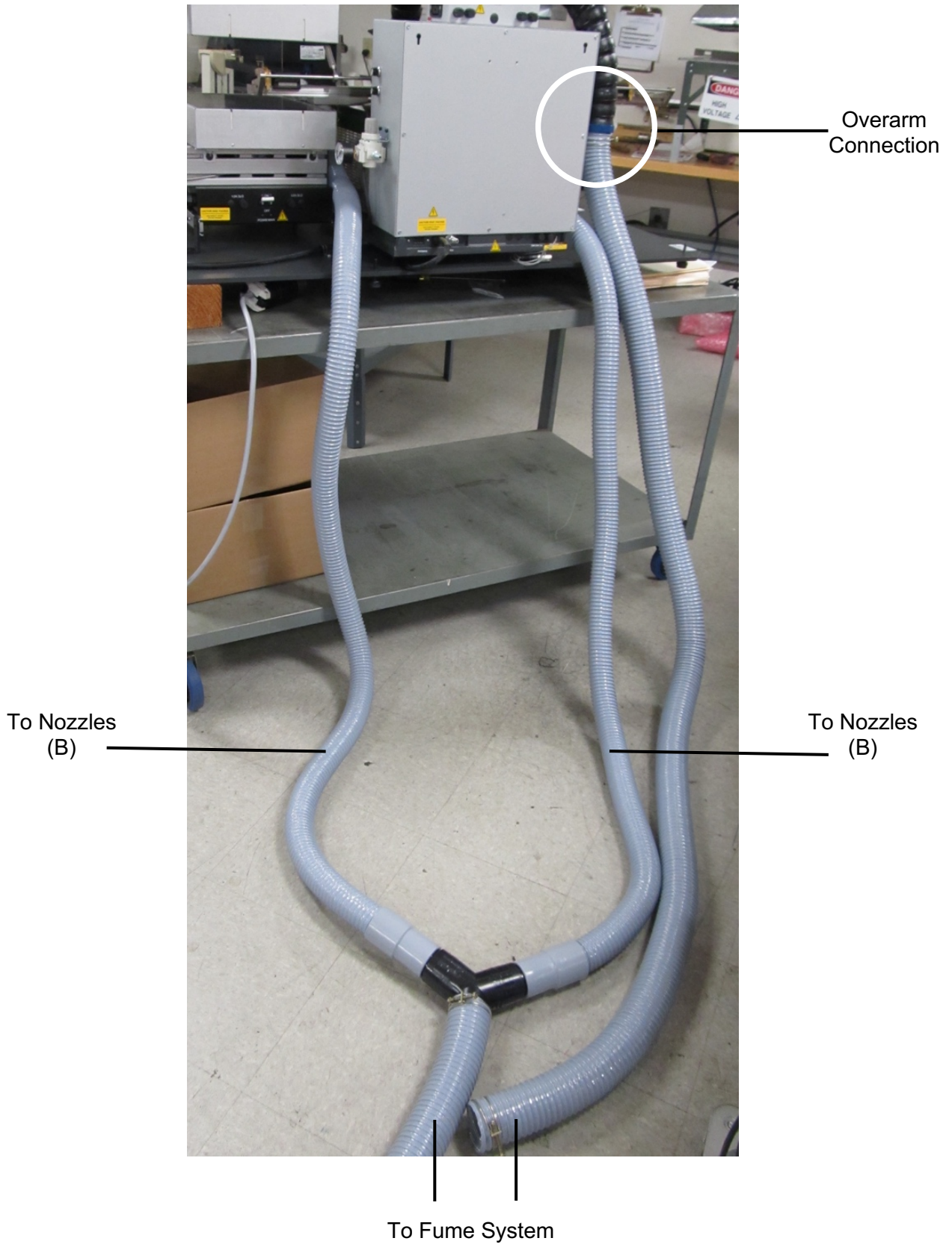

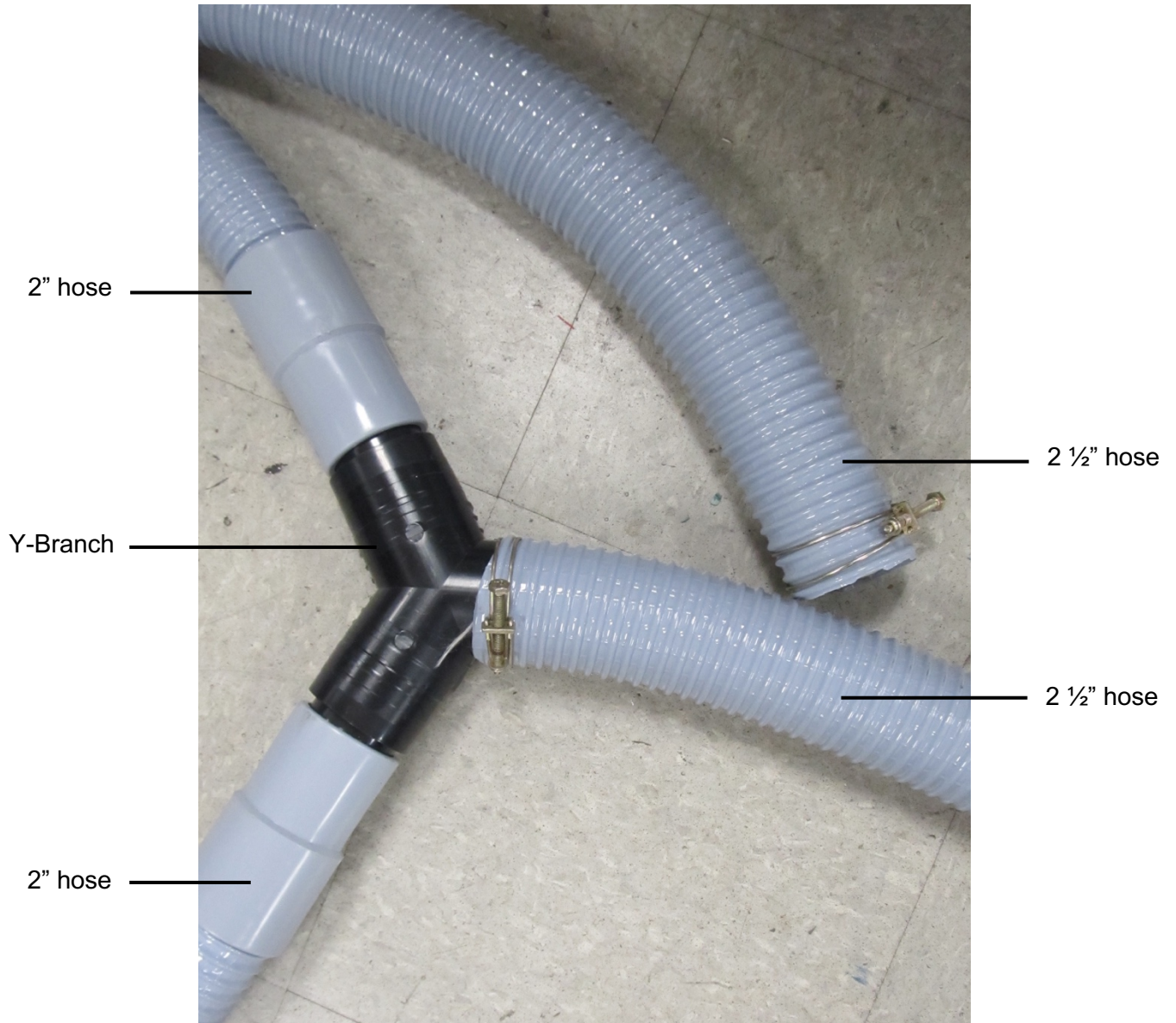

4: Processes & Applications

4	<i>Processes & Applications</i>	3
4.1	Adding Solder	3
4.2	Flow Well Set-Up	4
4.3	Cleaning Hood Set Up (option)	7
4.4	Solder Temperature	8
4.5	PCB Hole Cleaning Procedure	9
4.6	Soldering Replacement Component	9
4.7	Specific Production Soldering Applications	9
4.8	Temperature Controller (Watlow)	10
4.9	Temperature Controller (CAL 9900)	11
4.10	Operator Procedures	12
4.11	Set-Up and Process a PCB (step by step)	13
4.12	PCBRM System 5.2 - Soldering Sequence: Using Auto Mode for Soldering	21
4.13	PCBRM System 5.2 - Soldering Sequence: Using Manual Mode for Soldering	22
4.14	Removal Procedure	24
4.15	Component Replacement	25

4 Processes & Applications

4.1 Adding Solder

CAUTION:

USE INSULATED GLOVES WHEN WORKING AROUND HEATED AREA. BE CERTAIN THE MODE SWITCH IS IN THE OFF POSITION (NEUTRAL POSITION.)

- Remove Pot Cover (A) #2004.01.108.
- Insert Baffle Assembly (B) into Pump.
- Power up system by depressing main power and reset switch on the PCBRM module.
- When the pot reaches 500°F (260°C), place solder bars into pot until solder level is reached.
- Using gloves provided, place pot cover back on pot once solder has melted.

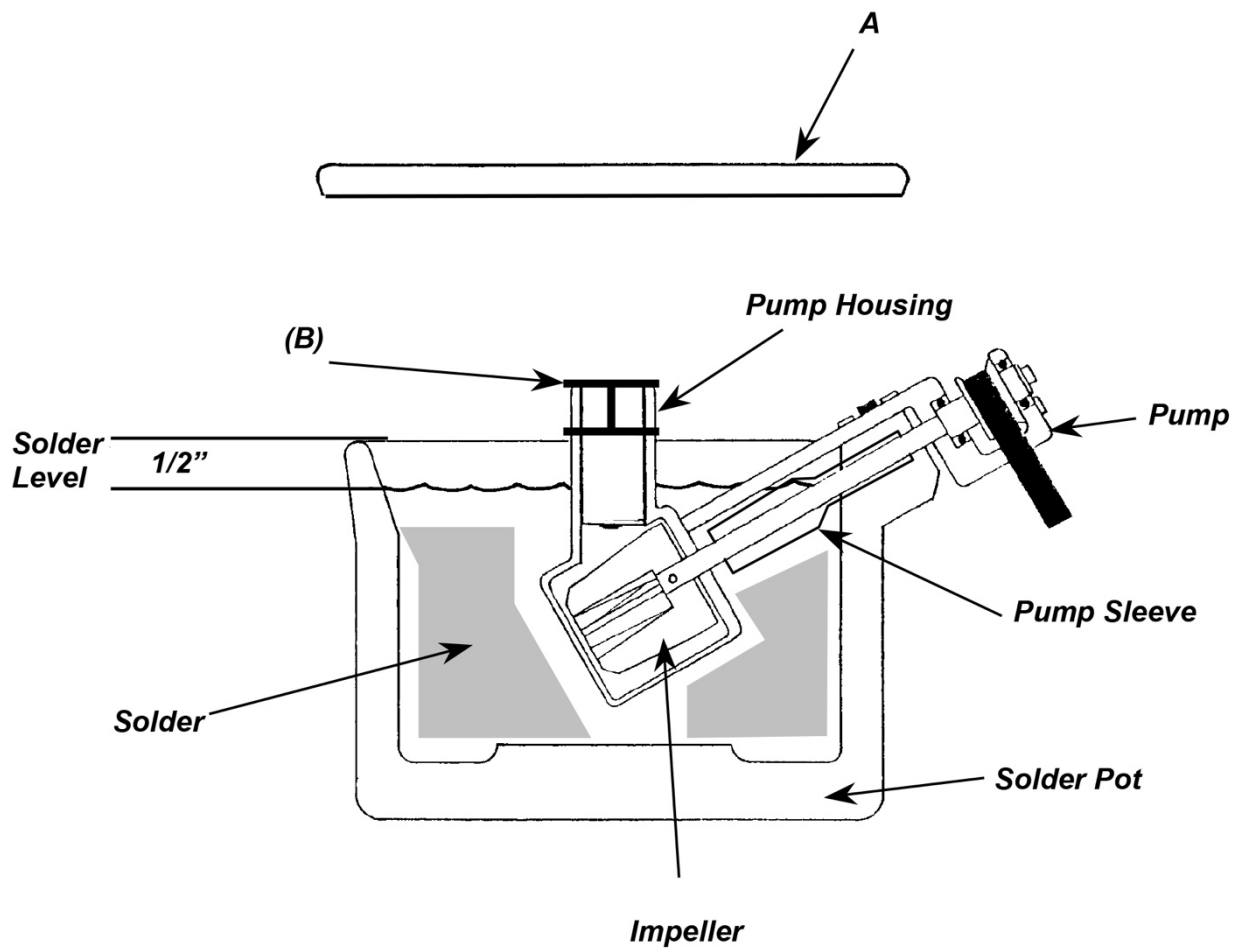

4.2 Flow Well Set-Up

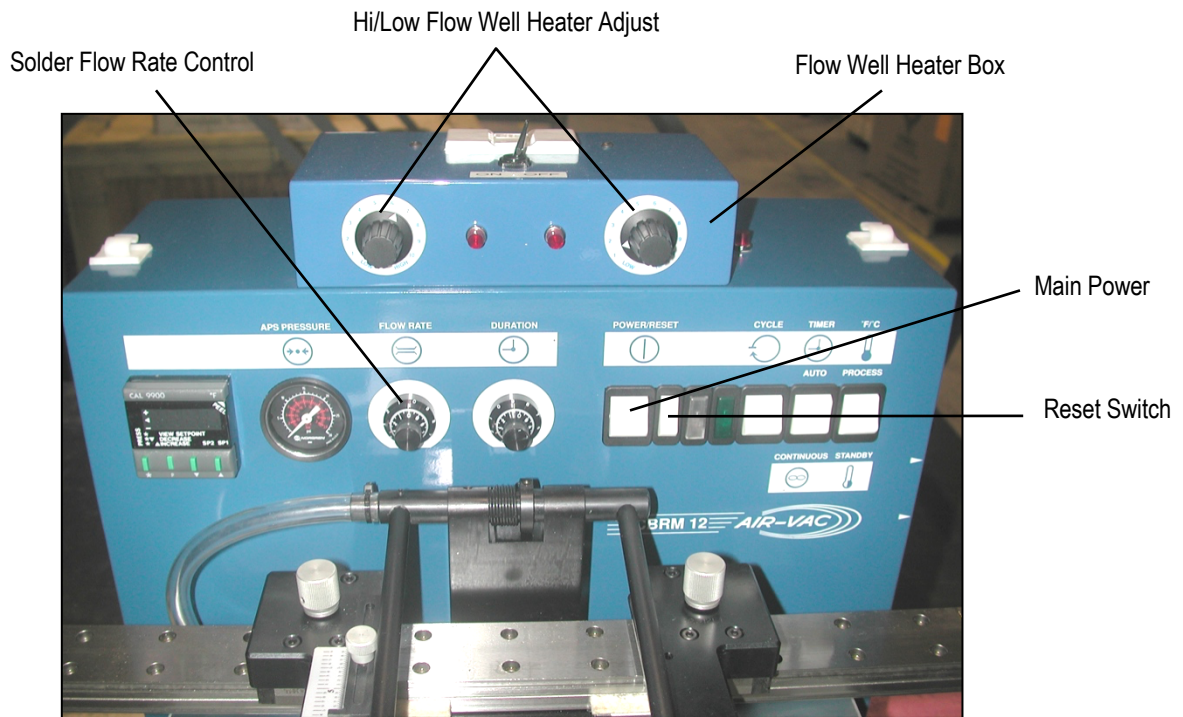

- Push the Main Power and Reset Switches. Process temperature is factory set at 500°F (adjust as required).
- Using insulated gloves, push down on flow well and insure it is completely seated on pump. If required, adjust Spring Tabs of well or tighten Clampable Shank (screw) as required to insure flow well maintains firmly positioned on pump.

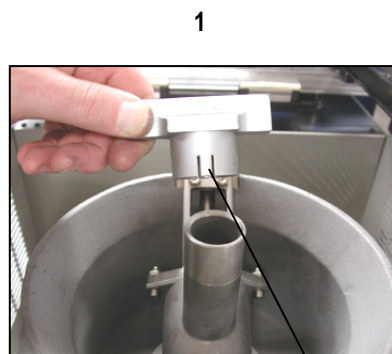

Spring Tabs

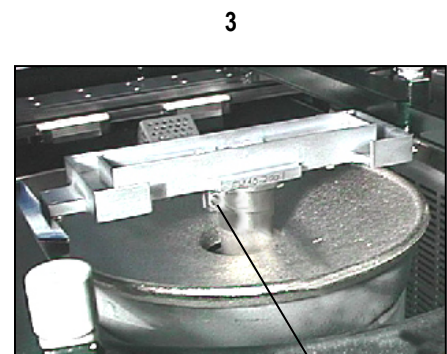
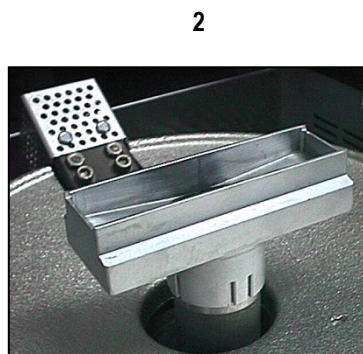

Screw

- Connect flow well heaters to power, if applicable. Adjust heaters as required.
- Allow machine to reach and stabilize temperature—typically 45 minutes.
- After flow well has heat soaked for 15 minutes, set Solder Flow Rate Control to zero. Mode Switch and Cycle Machine set to Continuous. Slowly increase Solder Flow Rate Control until solder fills the flow well and starts flowing over the ends.
- Solder may solidify in flow well if not heat soaked. Do not increase flow rate. Allow flow well to heat soak further.
- Select Mode Switch to Off position (center).

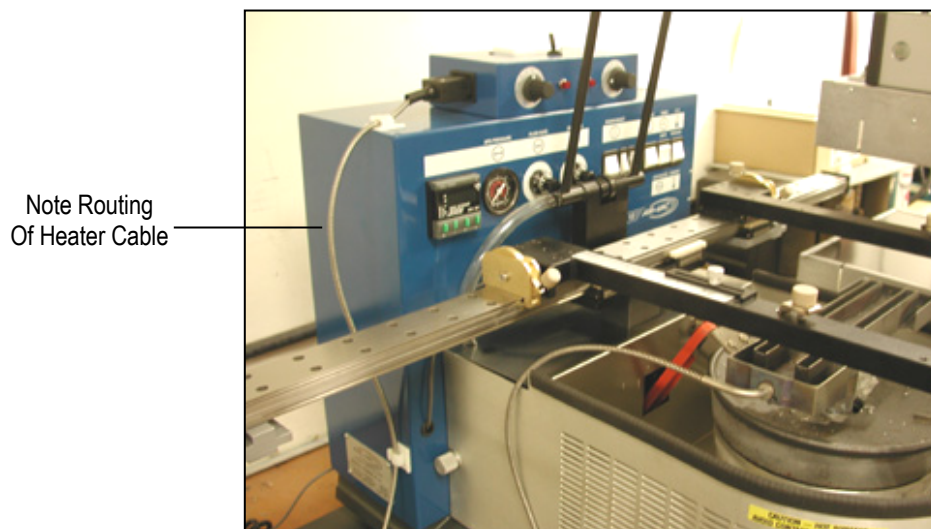

- Using the Z-Axis Height Adjustment Wheel, lower carrier to allow Carrier Arms to touch side of Flow Well.
- Adjust Flow Well parallel to carrier arms or use edge of a pcb as a guide to square the flow well as shown in photo.

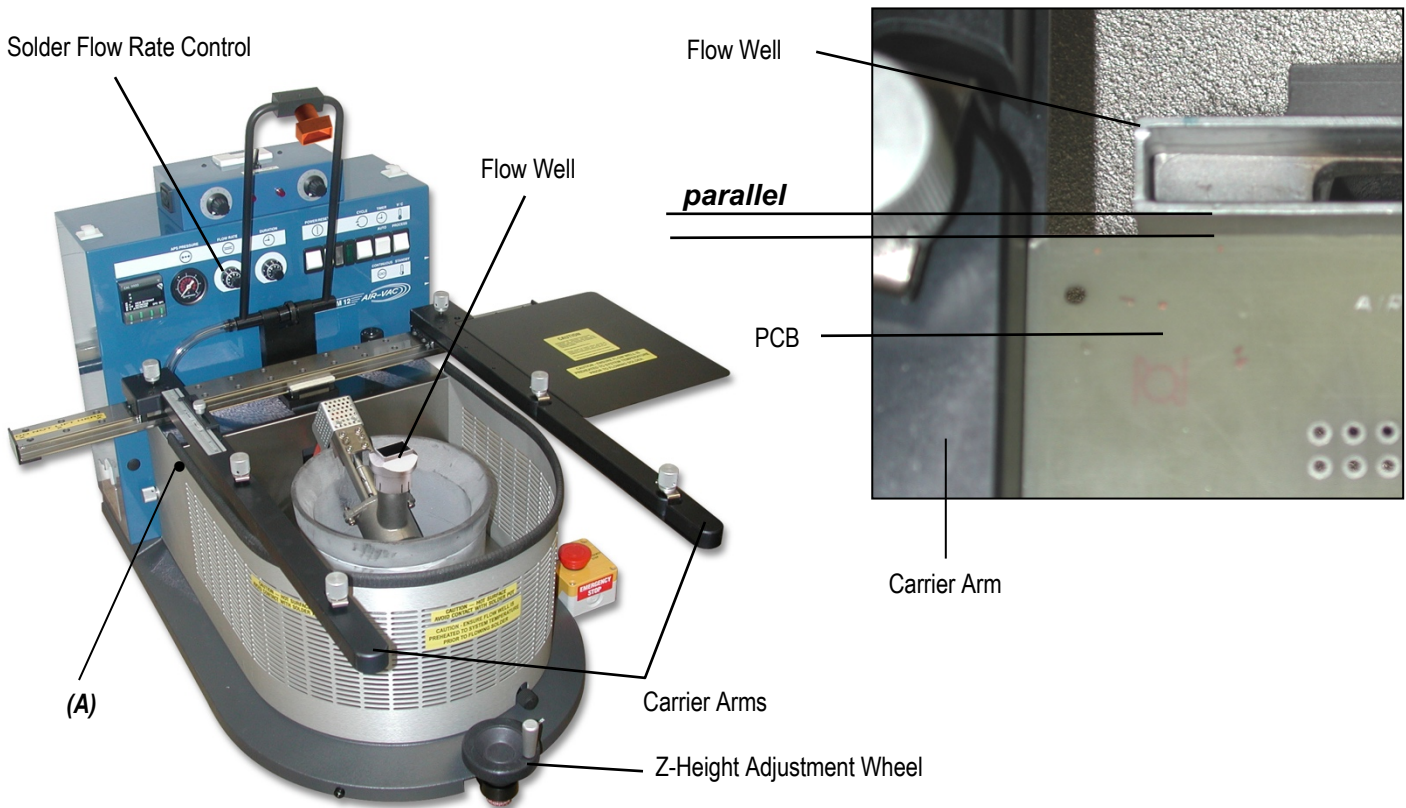

Adjusting PCB Height:

- A space of approximately 1/16" between the top of the flow well and the bottom of the pcb. Molten solder needs to flow through this space, contact all leads and flow freely back into the solder pot. Use Z-height adjustment wheel to adjust.
- **PCBRM System 5.2** – Once height is set, loosen and then lock the z-height adjust (A). Once set, unit is set for repetitive processes.

CAUTION:

INSUFFICIENT CLEARANCE COULD FORCE THE SOLDER TO FLOW UP THROUGH THE BARRELS OF THE BOARD AND FLOOD THE TOP OF THE BOARD. IT COULD ALSO CREATE A SAFETY CONCERN FOCUSING SOLDER UNDER PRESSURE OUT OF NARROW FLOW WELL/PCB OPENINGS. SOLDER CAN DEFLECT ALONG THE BOTTOM OF THE PCB TO ADJACENT AREAS.

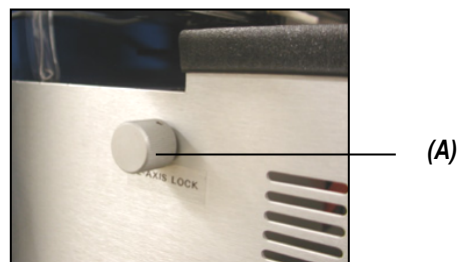
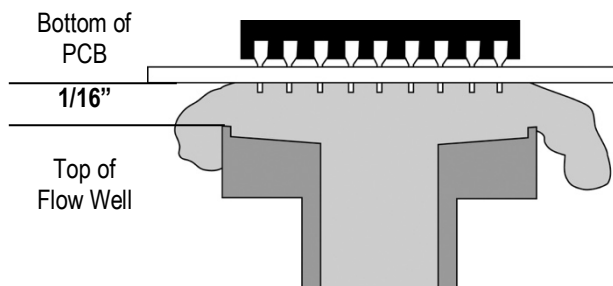

- Too great of a clearance could prevent the solder from reaching the entire lead pattern.
- Cycle machine. With flow rate at zero, switch mode switch to “continuous” mode and slowly adjust Solder Flow Rate Control to produce a level flowing solder wave.

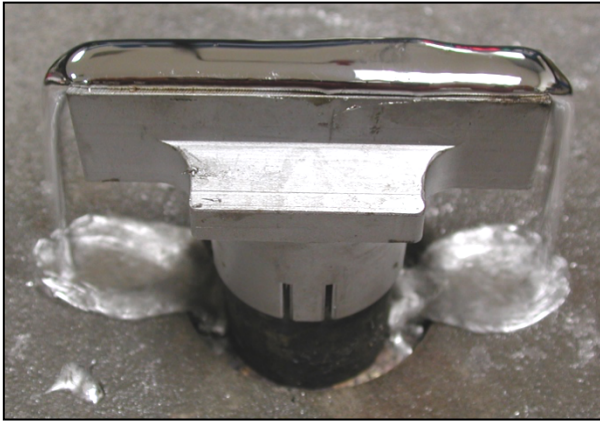

4.3 Cleaning Hood Set Up (option)

Hood must be positioned exactly over flow well with the faces of the hood and flow well parallel and square to one another.

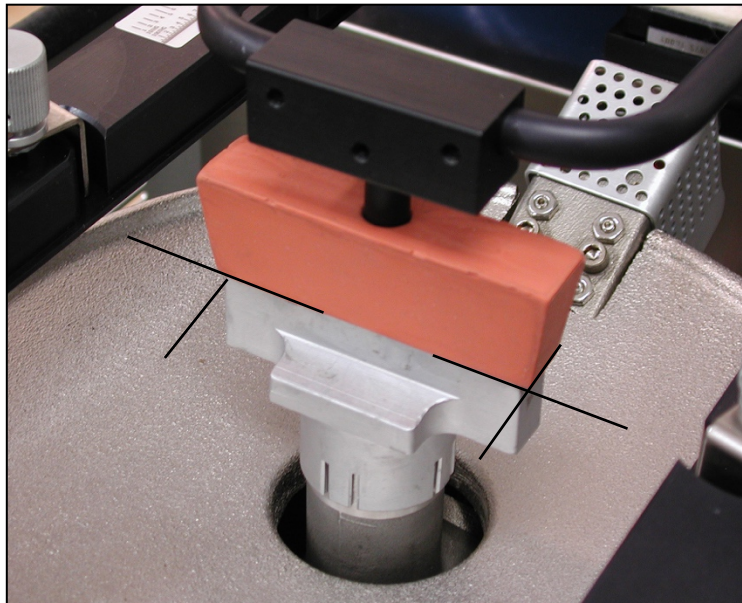

APS System (option)

- Set Air Regulator to 5-7 psi.

Note

DO NOT SET ABOVE 15 PSI. AIR PRESSURE MAY DISPERSE MOLTEN SOLDER.

FOR SOLDERING APPLICATIONS PRESSURE MAY BE SET TO ZERO (OFF) TO ELIMINATE NOISE.

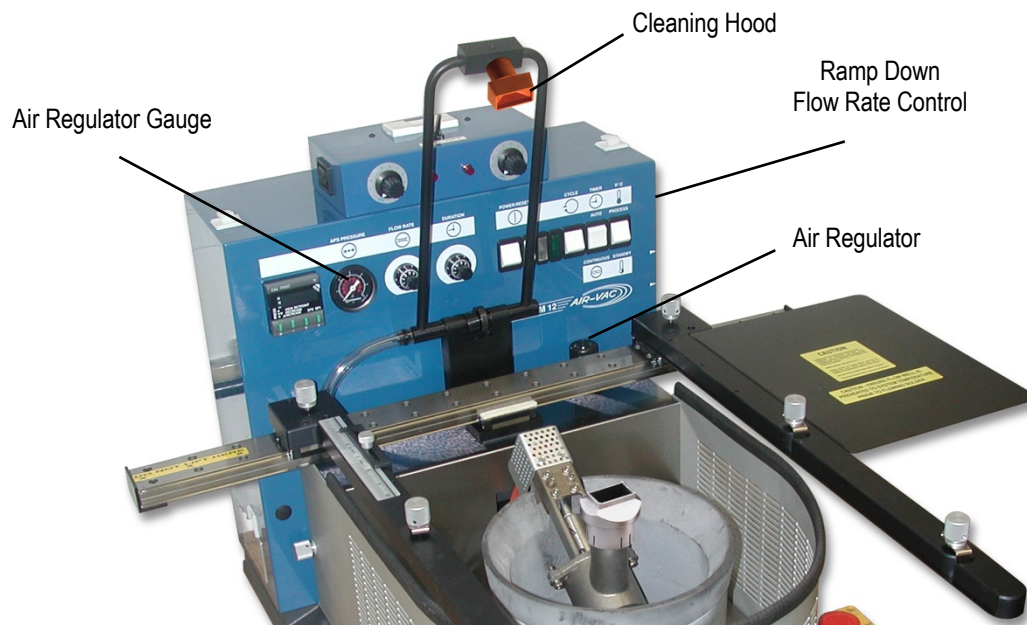

- Cleaning Hood is generally used for removal applications. Set Ramp Down Flow Rate Control to “10” to minimize time delay of air system when solder flow has ended.

4.4 Solder Temperature

Pot temperature is factory set at 500°F (260°C). Applications may require different temperatures. The temperature controller can be easily set by using the UP and DOWN arrows to select the desired temperature.

4.5 PCB Hole Cleaning Procedure

The hole cleaning operation starts immediately at the end of the component removal procedure. Referring back to the component removal cycle, there will be an audible signal that indicates solder has stopped flowing against the PCB. At this point, lower the air cleaning hood. It is important that sufficient downward pressure be applied to insure a good seal between the hood and board surface. However, excessive pressure can force the board to contact the flow well stand offs.

Low pressure air comes on automatically 1½ seconds after the solder stops flowing, forcing the molten solder to drop from the holes into the empty flow well. The 1½ seconds delay prevents pressurized air from coming in contact with the flowing solder.

The bottom of the PCB may have bridging or icicling caused by the moving air. The next operation of resoldering of the replacement component will eliminate these conditions.

4.6 Soldering Replacement Component

After the holes have been cleaned, flux the leads of the replacement component, insert into PCB, and start the cycle to solder the component. Where leads are “free”, exert a slight downward force on the component to prevent “floating” of the component when the solder wave contacts the leads.

4.7 Specific Production Soldering Applications

In addition to component removal and replacement, the PCBRM15 is commonly used for Selective Soldering in the production process.

Small Sub-Assemblies

The PCBRM12 has many advantages compared to hand soldering sub-assemblies. The average solder cycle is 5-10 seconds regardless of the number of component leads. The heat exposure on the PCB is less, since the average solder temperature is 500°F, compared to soldering irons that are higher. Operator skill is minimal, since the solder cycle is controlled and the entire area is soldered at once.

Seating Soldered Components

In production wave soldering, a common problem is the “floating” of components that do not have clinched leads resulting in components that are not properly seated. These components can be positioned over the flow well and as the solder is flowing and all joints are molten, downward force may be used to properly seat the component.

Selective Soldering



For a variety of reasons, many components cannot be on the board during the production wave or drag soldering and cleaning operation. These components have to be soldered on the board individually in a secondary operation. Rather than hand soldering these components, they can be positioned over the flow well and wave soldered without reflowing components already on the board. Very common selective soldering applications are for edge connectors that cannot be on the board due to pallet restrictions and components like switches and relays that cannot go through the cleaning process.

4.8 Temperature Controller (Watlow)

Programmable Set Points. The Programmable Digital Readout Temperature Controller has two set points that are programmable. "Set point one (SP1)" is the process temperature; "set point two (SP2)" is the standby/interlock temperature.

Process Temperature (SP1). The process temperature determines the temperature of the flowing solder during the rework and soldering cycles. The controller is connected to a thermocouple located at the bottom of the solder pot. The actual temperature contacting the bottom of the printed circuit board is approximately 10°F less than the process temperature, which is factory set at 500°F.

Standby/Interlock Temperature (SP2). *The standby/interlock temperatures are the same temperature.* The standby temperature minimizes oxidation by automatically reducing the temperature when the module is not being used. The purpose of the interlock temperature is to prevent the pump motor from operating until the solder reaches a molten condition. SP2 is factory set at 70°F less than the process temperature (500°F - 70°F = 430°F).

	<ol style="list-style-type: none"> 1. Actual Temperature (110) 2. Process Temperature (500)
	<ol style="list-style-type: none"> 3. Standby/Interlock Temperature (-70)
	<ol style="list-style-type: none"> 4. Overtemp Temperature (617)

4.9 Temperature Controller (CAL 9900)

Programmable Set Points. The Programmable Digital Readout Temperature Controller has two set points that are programmable. Set point one (SP1) is the process temperature; set point two (SP2) is the standby/interlock temperature. The temperature selector switch determines which set point is activated.

Process Temperature (SP1). The process temperature determines the temperature of the flowing solder during the rework and soldering cycles. The controller is connected to a thermocouple located at the bottom of the solder pot. The actual temperature contacting the bottom of the printed circuit board is approximately 10°F less than the process temperature, which is factory set at 500°F.

Standby/Interlock Temperature (SP2). *The standby/interlock temperatures are the same temperature.* The standby temperature minimizes oxidation by automatically reducing the temperature when the module is not being used. The purpose of the interlock temperature is to prevent the pump motor from operating until the solder reaches a molten condition. SP2 is factory set at 70°F less than the process temperature (500°F - 70°F = 430°F).

To Change SP1 or SP2 – Follow These Procedures

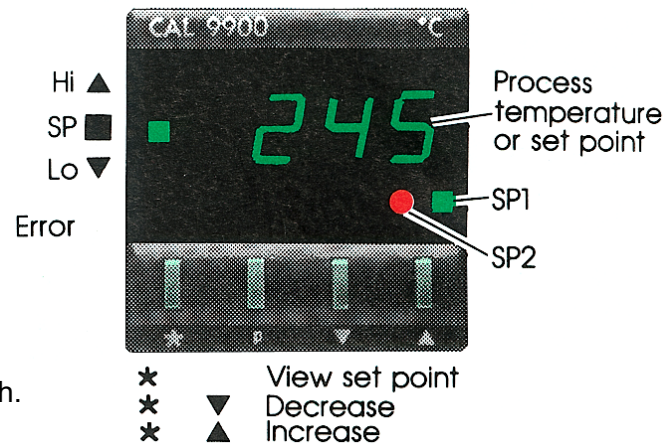

- SP1 Temperature:
 1. With the power and reset switches on, press the *key and the SP1 setting will flash.
 2. By holding the *key down and pressing the ▼ and ▲ keys, the SP1 setting may be changed.
 3. When the keys are released, the display automatically returns to actual solder temperature.
- SP2 Temperature
 1. With the power and reset switched on, depress the “P” key with a pointed object. The digital display will show numbers with a decimal point and the number to the right of the decimal point will flash.
 2. Use the ▼ and ▲ keys to bring the flashing number to 2 at the right side of the decimal point.
 3. Press the *key to change the left side of the decimal. Press the ▼ and ▲ keys to set the differential temperature (range available is 0 - 99°F).
 4. Press “P” to lock in memory. Display will automatically return to actual solder temperature.

Note:

SP1 AND SP2 LIGHTS WILL REMAIN LIT UNTIL EACH TEMPERATURE IS REACHED. THE ▲ LIGHT INDICATES A TEMPERATURE HIGHER THAN PROCESS TEMPERATURE. THE ▼ INDICATES A TEMPERATURE LOWER THAN THE PROCESS TEMPERATURE.

4.10 Operator Procedures

4.10.1 Safety Instructions & Recommendations

CAUTION:

OPERATION OF THIS MODULE INVOLVES PUMPING OF MOLTEN SOLDER. ALL NORMAL SAFETY PRACTICES MUST BE OBSERVED.

Personnel

- Safety glasses should be worn at all times.
- Wear protective gloves when working with solder. Solder could contain tin and lead, which are hazardous materials.
- Place any waste solder or dross in a heat resistant dross container.
- Always wash hands after working with solder.
- Use caution if wearing loose clothing while operating this machine as loose clothing can fall into the molten solder. Always secure loose clothing before operating this equipment.
- Never eat, drink, or smoke while working with solder.
- Only trained operators and technicians should work on this equipment.

- Molten solder will cause severe burns. Use extreme caution when operating this equipment. Heat resistant gloves are recommended particularly when placing and removing Flow Wells, removing dross, adding solder or removal solder and during maintenance.
- Report any problem to supervisor.

Equipment

- Flow Wells must heat soak on pump housing before attempting to flow solder. Failure to heat soak Flow Well can cause solder to solidify in the Flow Well openings.
- Flux vapors result from soldering or desoldering. Fresh air must be provided. A venting system or fume extraction system is recommended.
- Slowly increase flow rate to reach proper flow for the flow well. Do not increase flow rate if solder solidifies. Allow flow well to heat soak slowly.
- Do not allow solder to flow outside the confines of the solder pot.
- Do not cool flow well with liquid (water). Use only ambient air environment to cool flow well.
- During operation do not allow PCB to seal against flow well.
- Keep all covers on. Do not open machine covers unless you are at the Main Menu Screen for basic maintenance.
- Keep hands clear of moving parts. Do not reach into the machine during operation.
- Do not override safety interlocks.
- Check area for any loose parts or tools that could cause mechanical interference.
- Do not place anything on the top of the machine.
- In the event of an emergency, press the Red Emergency Stop button located on the front of the machine. Locate this Emergency Stop button before operating this machine.
- Shut off electrical power and unplug machine when servicing any area of the machine.
- If a malfunction should arise, depress the Emergency Stop button to stop operation.
- The machine should not be operated unless the solder pot cover and flow well are in place.
- Heat resistant gloves should be worn when placing and removing flow wells, removing dross, and adding or removing solder.
- The machine should not be moved when the solder is molten.
- Refer to material safety data sheet of solder, flux, or any other product used in conjunction with module. Follow all warning labels and instructions.

4.11 Set-Up and Process a PCB (step by step)

Set-up:

NOTE:

BE CERTAIN THAT THE PUMP BAFFLE IS INSTALLED INTO THE PUMP. ADJUST Z-AXIS TO ITS HIGHEST POSITION. INSTALL FLOW WELL AND CLEANING HOOD IF SO EQUIPPED.

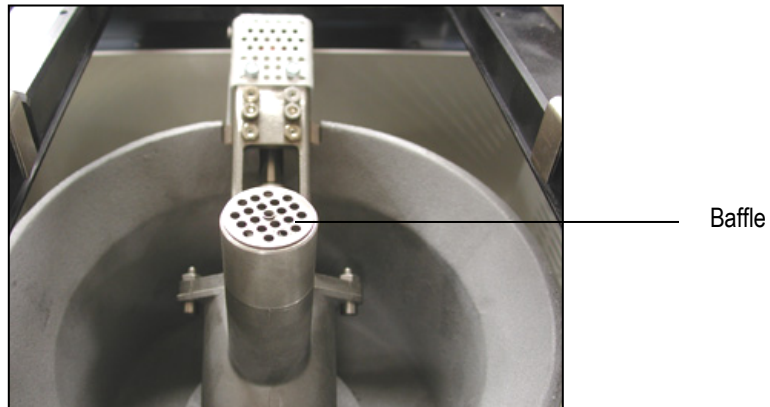

1. Move X-Axis carrier all the way to the left.
2. Move the carrier arms to an approximate position on the X-Axis to hold the board.
3. Lock the left arm to the X-Axis rail.

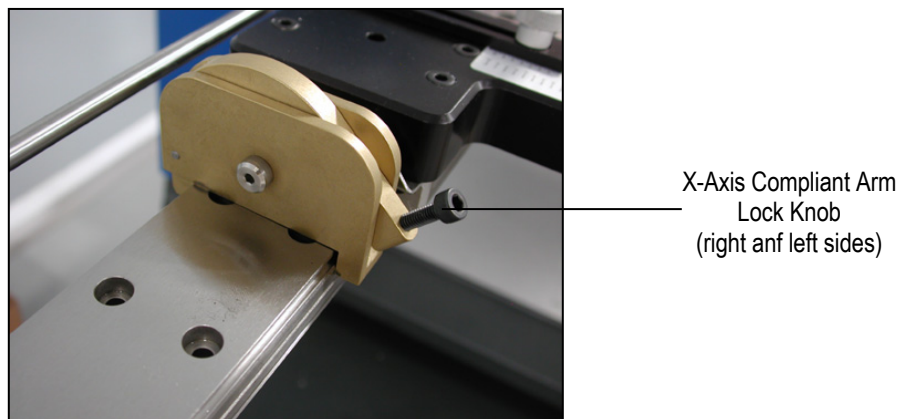

4. Hold PCB in left arm while moving the right arm to the board. Lock right arm.

- 5. Move X-Axis carrier to the right. Be certain there is enough travel to locate PCB to the flow well. Adjust arms as required.

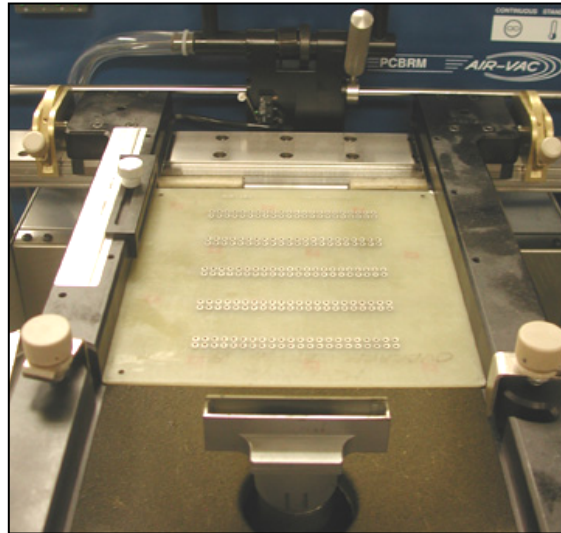

- 5A **For System 5.2**, be certain there is enough travel to locate the PCB in the preheater. Adjust arms left or right as required.

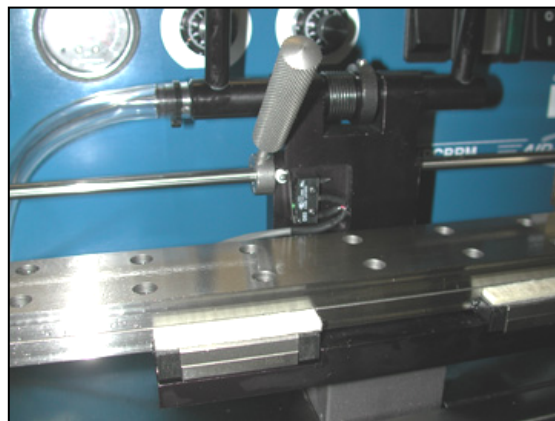

- 5B Move the left X-Axis lock to the right to hard stop the center bracket and micro switch.

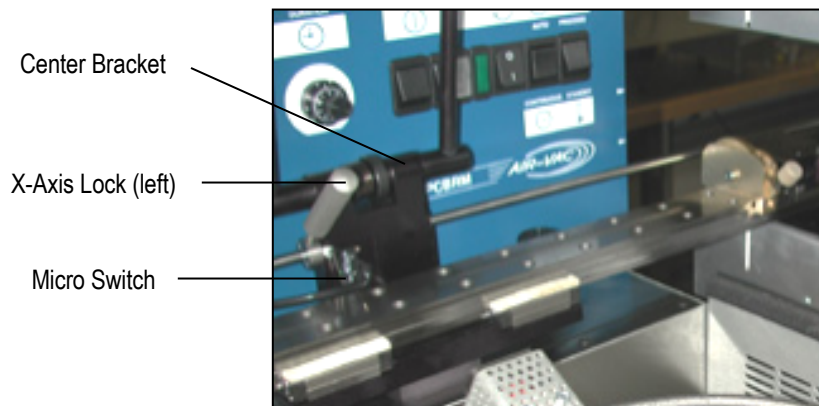

NOTE:

FOR SYSTEM 5.2, BE CERTAIN THAT THE PREHEATER IS IN ITS FORWARD POSITION AND LOCKED IN POSITION.



Lock Knob

6. Move carrier to bring PCB to the flow well location.

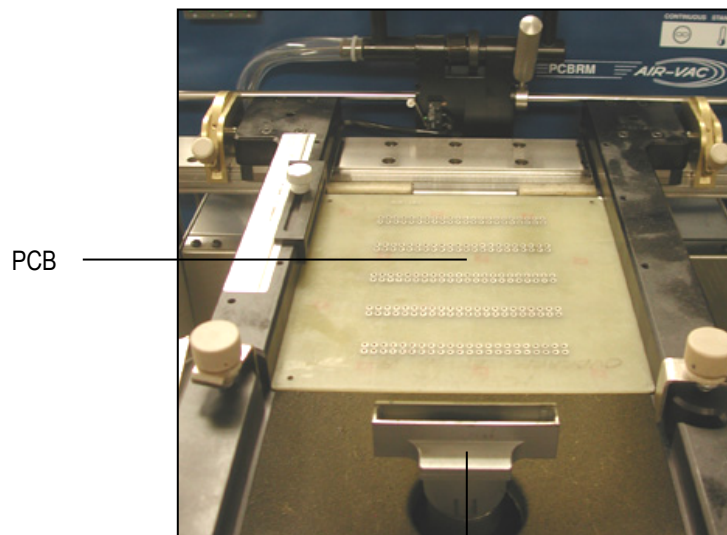

Flow Well

7. Lower Z-Axis to bring the PCB to contact the side of the flow well and square flow well to PCB.

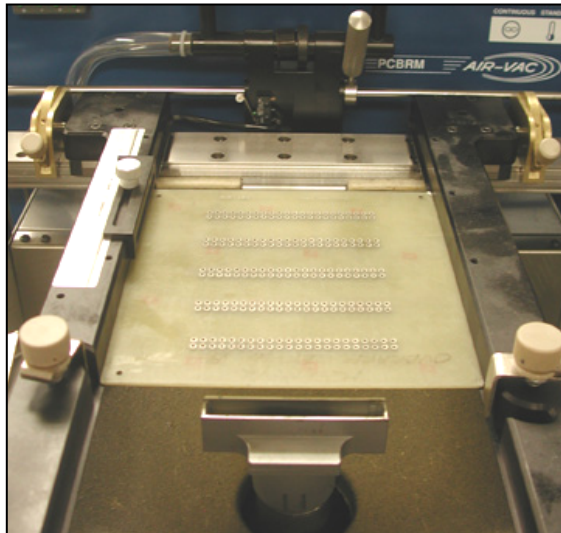

8. Raise Z-Axis using Z-Axis height adjustment wheel and adjust PCB to a height of 1/16" above the flow well.

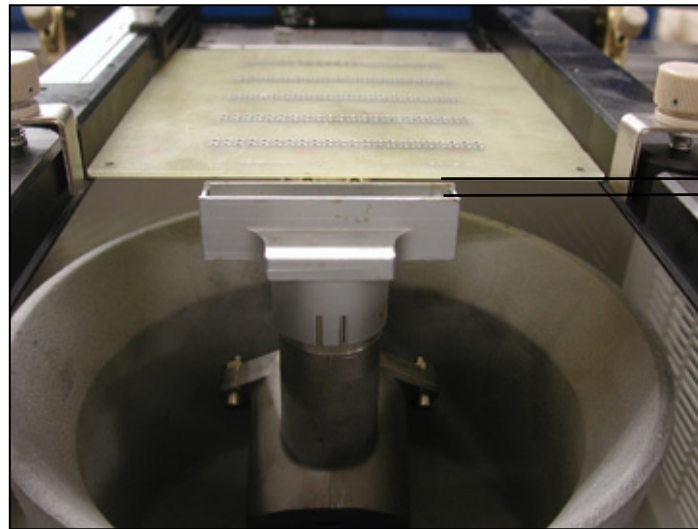

1/16"

- For System 5.2, loosen Z-Axis lock knob and then tighten. The Z-Axis height is now set for repetitive applications.



Z-Axis
Positioning Knob

9. Move PCB in the Y-Axis and align component/lead pattern over the flow well. Use the APS over arm and cleaning hood to locate, if so equipped. Lock the X-Axis carrier lock.

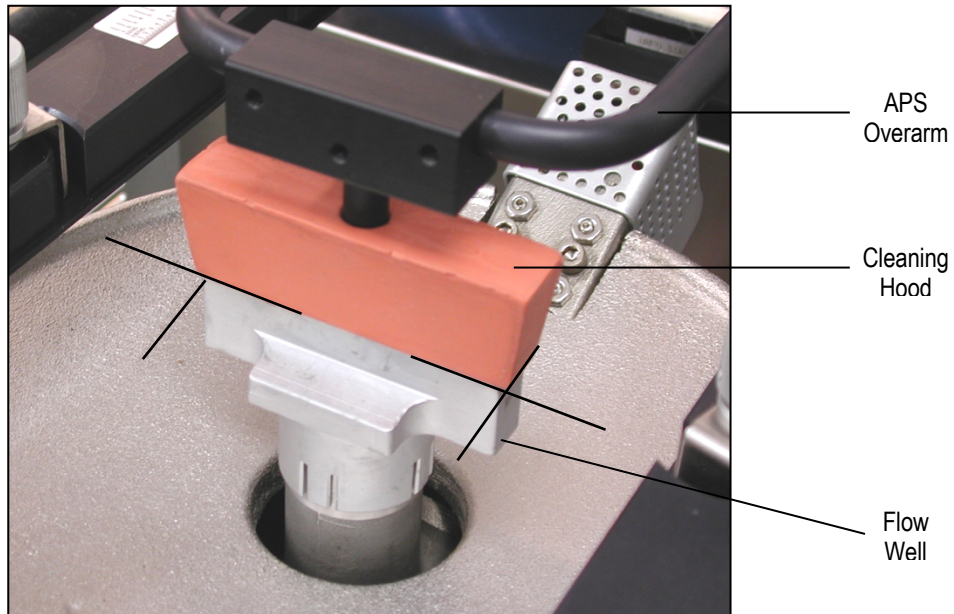

10. Adjust the Y-Axis stop to set position of PCB in the carrier arms.
 - For System 5.2, move the right X-Axis lock to the left until hand stop against center bracket.

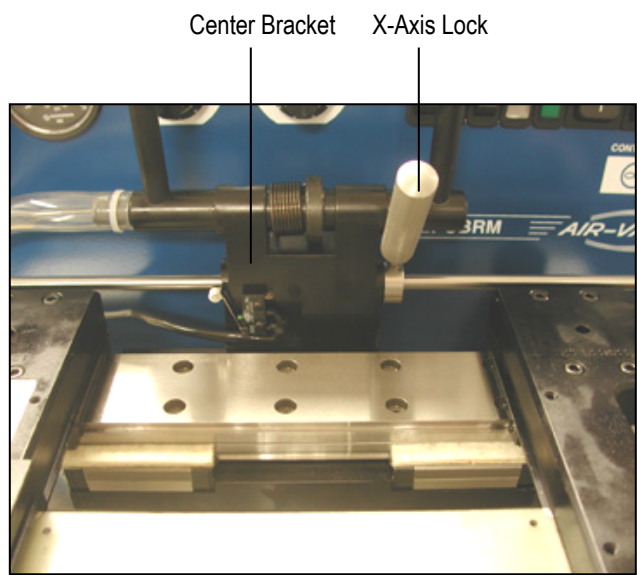
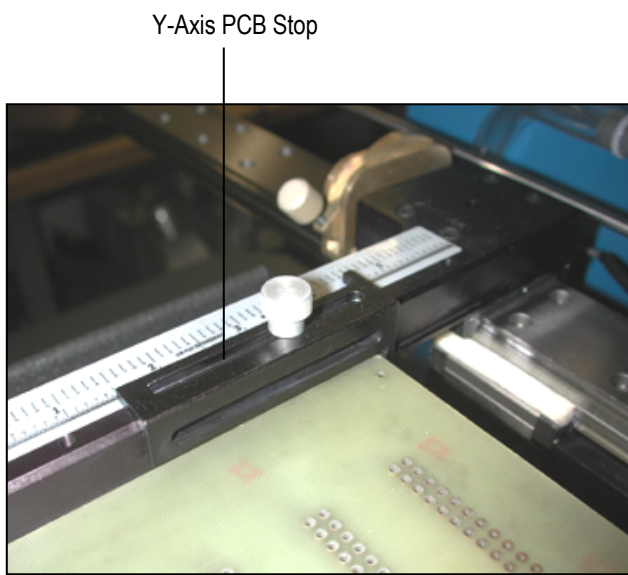

11. Remove PCB from carrier arms.
 - For System 5.2, unlock X-Axis carrier lock.

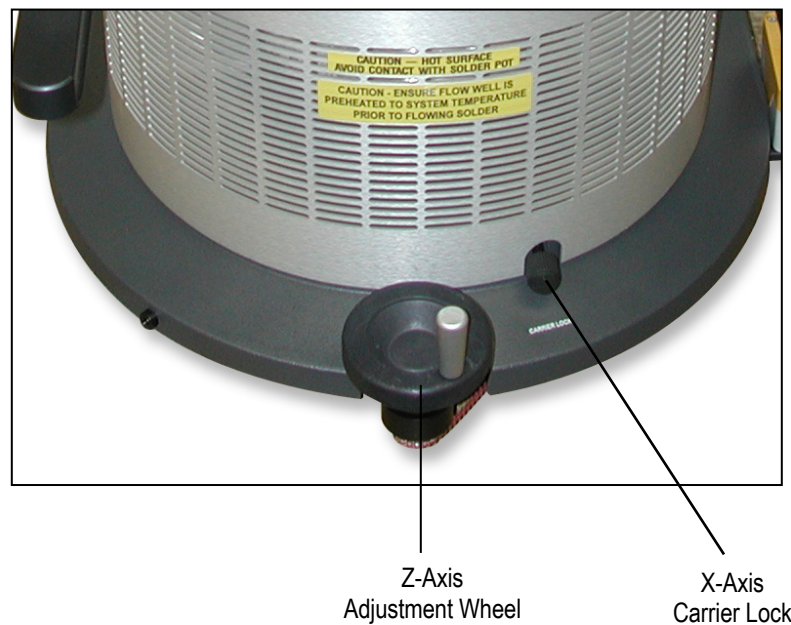

12. Turn on machine and let temperature stabilize. Adjust temperature as required.
 - For System 5.2 turn on preheater. Adjust temperature as required.

Note

ALWAYS HEAT SOAK FLOW WELLS FOR A MINIMUM OF 15 MINUTES BEFORE FLOWING SOLDER.

13. Set solder flow rate. Starting at zero, set mode switch to continuous.
14. Slowly increase flow rate until solder flows off the edge(s) of the flow well. Flow rate is now set for that flow well. Different flow rate is required for different size flow wells.

Solder Flow

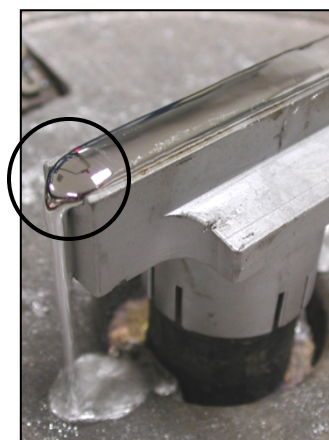
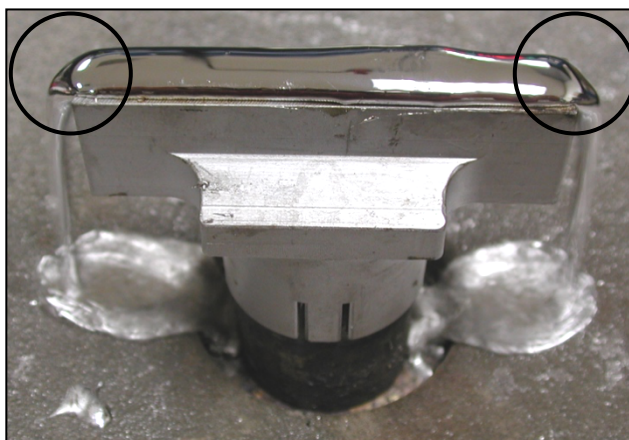

15. Set mode switch to auto (top) position.
16. Place PCB in carrier arms and lock in place with the board lock knobs.
 - **For System 5.2**, tape a type K thermocouple to the PCB using Kapton tape. Plug thermocouple into the temperature monitor box as required.
 - Set the temperature controller on the temperature alarm box to the desired temperature that the PCB needs to reach.
 - Move PCB into the preheater. When alarm sounds, temperature has been met.
17. Move PCB to flow well location.

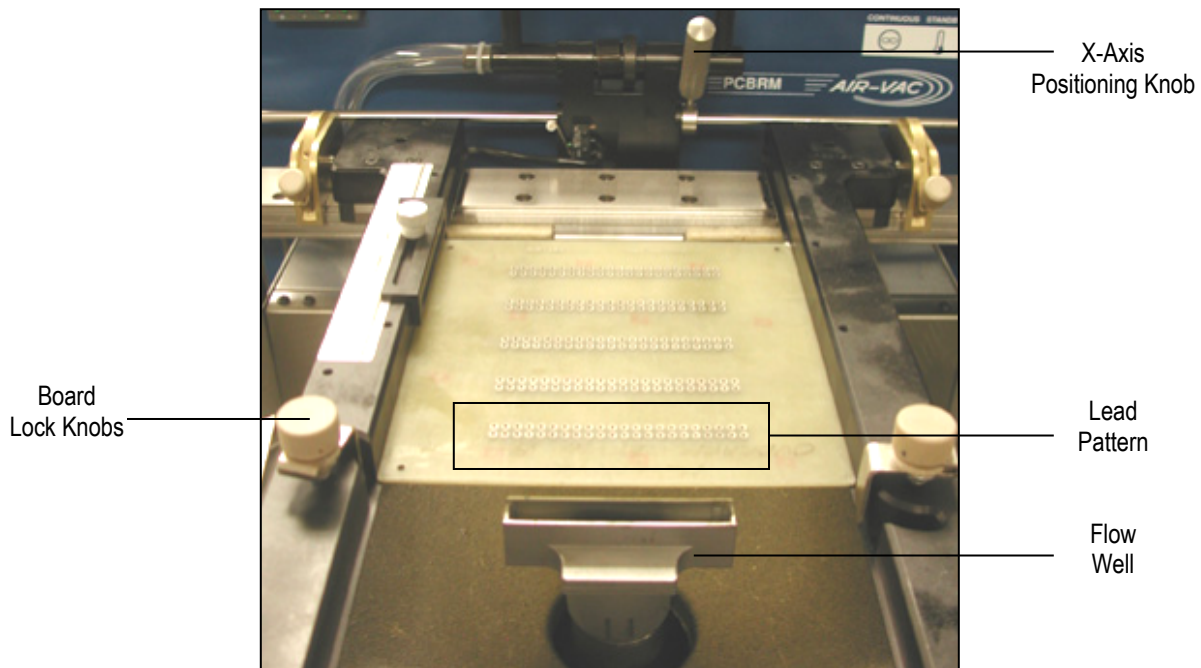

Mode Switch/Duration/Footswitch

NOTE

UNTIL DURATION (TIME) OF SOLDER FLOW HAS BEEN ESTABLISHED, SET THE DURATION TO THE MAXIMUM SETTING AND START AND STOP THE FLOW BY USING THE FOOTSWITCH (MANUAL MODE).

BY USING A STOP WATCH, THE DURATION CAN BE DETERMINED. THE DURATION SETTING IS A RELATIVE SCALE AND THEREFORE SETTING THE TIME WILL TAKE A COUPLE OF TRIES.

DURATION SCALE IS APPROXIMATELY 0 TO 60 SECONDS.

ONCE THE DURATION IS SET, LEAVE MODE SWITCH IN AUTO. WHEN PCB IS LOCATED OVER THE FLOW WELL, PRESS START ON THE FOOTSWITCH.

4.12 PCBRM System 5.2 - Soldering Sequence: Using Auto Mode for Soldering

Note

SOLDER FLOW AND DURATION MUST BE DETERMINED PRIOR TO THESE STEPS.

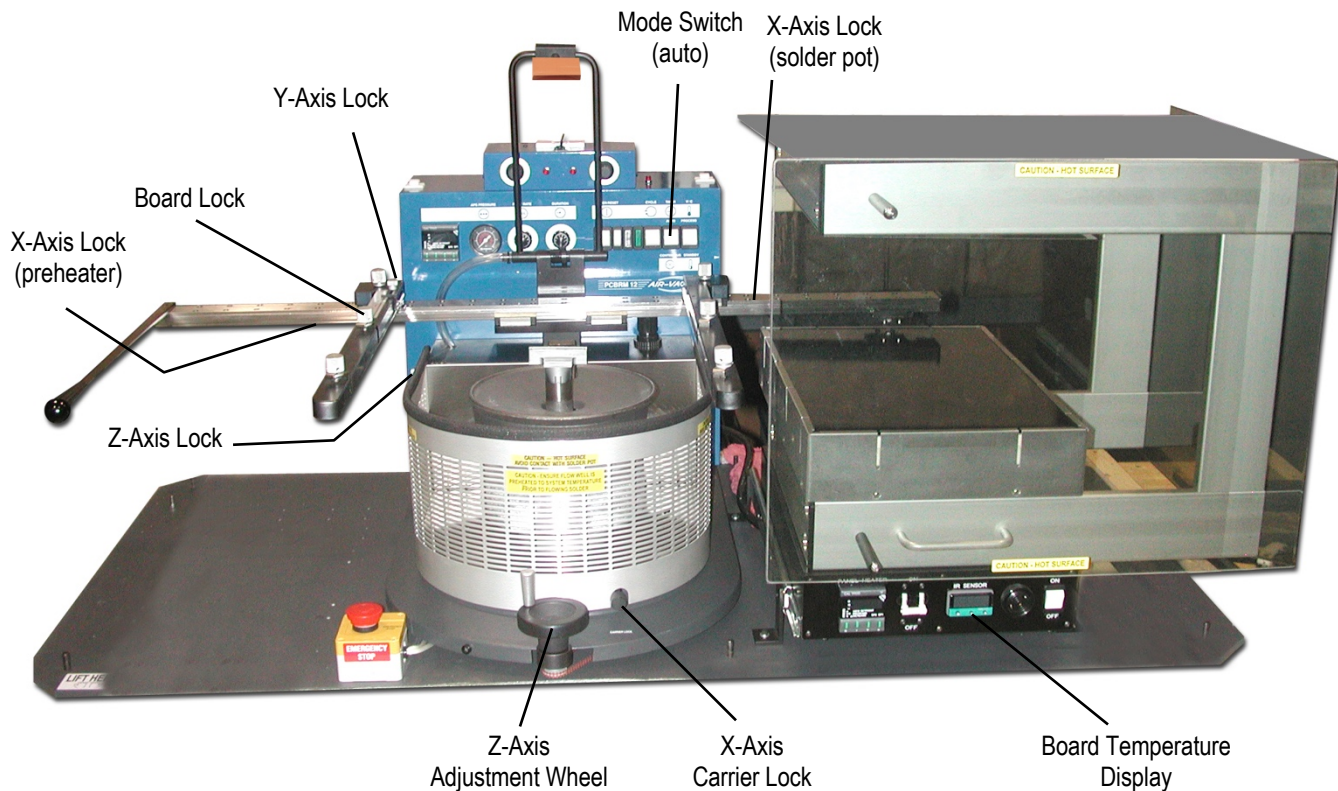

1. Install flow well.
2. Load board into carrier. Tighten board locks. If y-axis lock is used, position board to edge and tighten.
3. Slide board into preheater using the carrier handle until x-axis lock (preheat) is reached. Be sure carrier is in the top position to avoid hitting the flow well. Adjust z-axis adjustment if necessary. Carrier may be lowered to enhance preheating. Allow board to preheat to desired topside temperature. IR temperature sensor will monitor and display board temperature.
4. When board has reached desired temperature, alarm will occur. Slide board using the carrier handle until carrier hits the x-axis lock (solder pot).
5. Turn z-axis adjustment wheel until carrier hits z-axis lock **(System 5.2 only)**.
6. Press left side of footswitch to cycle machine. Solder cycle will occur.
7. Turn z-axis adjustment wheel to top position.
8. Using the carrier handle, slide board to unload/load position. Loosen board locks and remove board.
9. Repeat process.

4.13 PCBRM System 5.2 - Soldering Sequence: Using Manual Mode for Soldering

Note

SET SOLDER CYCLE DURATION CONTROL TO MAXIMUM SETTING. FLOW MUST BE DETERMINED PRIOR TO THESE STEPS.

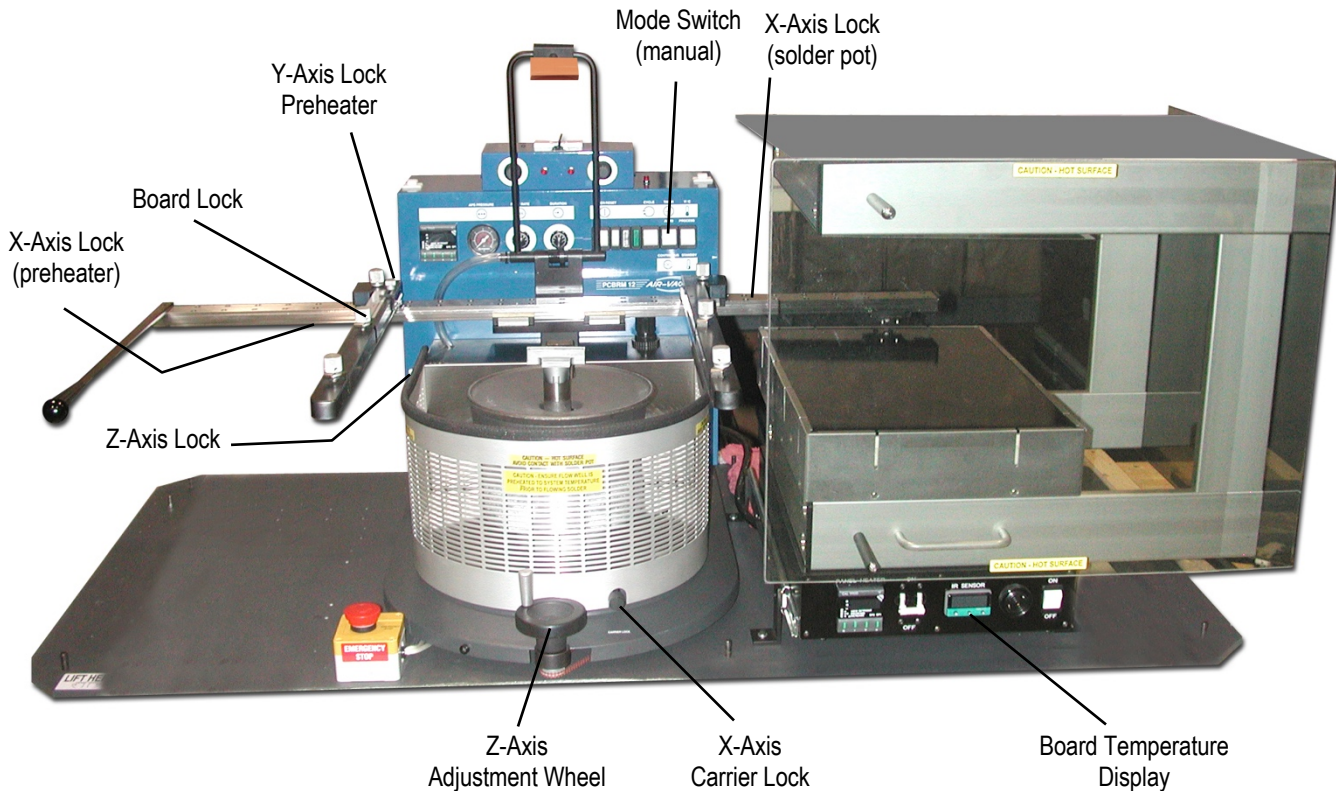

1. Install flow well.
2. Load board into carrier. If y-axis lock is used, position board to edge and tighten. Tighten board locks.
3. Slide board into preheater using the carrier handle until the x-axis lock (preheater) is reached. Adjust z-axis adjustment when necessary. Be sure carrier is in the top position to avoid hitting flow well. Carrier may be lowered to enhance preheating. Allow board to preheat to desired topside temperature. IR sensor will monitor and display board temperature.
4. When board has reached desired temperature (alarm will occur) press footswitch to activate solder flow. Skim off dross, if necessary.
5. Slide board over solder wave, using the carrier handle—until carrier hits x-axis lock. Turn carrier lock to set.
6. Turn Z-Axis Adjustment Wheel until carrier hits z-axis lock (**System 5.2 only**).
7. Allow sufficient time for reflow.
8. Slowly turn Z-Axis Adjustment Wheel moving board upward to allow solder to slowly peel from the component leads to alleviate bridging.
9. Turn off solder flow by pressing right side of footswitch.
10. Turn Z-Axis Adjustment Wheel to top position. Loosen Carrier Lock. Slide board away from solder pot using the carrier handle. Remove board.
11. Repeat process.

Process Notes:

- It may be desired to turn on solder flow while board is in the preheat position to allow flow well to heat soak and dross to be skimmed prior to soldering.
- Reduce bridging by adjusting Ramp Down Flow Rate to zero (0). Or, manually raise board slowly with Z-Axis Adjustment Wheel while solder is still flowing.
- Flux entire lead area. It may be required to flux topside of board. Allow sufficient temperature to be achieved to activate flux.
- Board must be level to solder wave. Fixturing may be required.
- The vertical position of the board is critical for proper soldering results. Allow solder to contact all leads, but sufficient clearance for solder to flow. Bridging may be reduced by raising carrier position and allowing solder to wick up the leads.
- Using tacky flux may allow more flux to remain during reflow, reducing bridging.
- Increasing preheat may be required for thermal challenging and lead free assemblies.
- It may be desired to lower the process temperature and increase process time if the board is prone to delamination and/or discoloring.

4.14 Removal Procedure

4.14.1 Set Up

- Set Ramp Down Flow Rate to 10.
- Set Air Regulator to 5-7 psi.
- Follow same procedure for automatic soldering procedure. If manual soldering procedure is used, the operator must press the footswitch to stop the solder pumping and activate the hole cleaning system.

4.14.2 Operation

Use automatic or manual procedure as described in soldering section up to when solder is contacting the board.

Allow sufficient time for solder to contact component leads for easy removal.

Observe component leads and when all leads are molten, lift the component from the board using an extractor tool that firmly grasps the component body. If solder is still flowing, interrupt cycle by pressing the right side of the footswitch. Component should lift out easily.

The hole cleaning operation starts immediately at the end of the component removal procedure. There will be an audible signal that indicates solder has stopped flowing against the board. At this time, lower the Air Cleaning Hood. It is important that sufficient downward pressure be applied to insure a good seal between the hood and board surface. Be sure entire area is sealed. Air leakage will prevent maximum effectiveness of system. Hold in place during the entire time the air is applied.

Low pressure air comes on automatically 1 ½ seconds after the solder stops flowing, forcing the molten solder to drop from the holes into the empty flow well. The 1 ½ seconds delay prevents pressurized air from coming in contact with the flowing solder.

The bottom of the board may have bridging or icicling caused by the moving air. The next operation of resoldering of the replacement component will eliminate these conditions.

Depending upon the heat sink characteristics of the board, the number of leads, and shape of the lead pattern, there will be some holes that will not be completely clear of solder.

Component Removal Process Notes

Board must be clamped. If not, when removing the component leads may catch in the barrels and lift the board away from the solder wave during reflow.

Do not set Air Cleaning System too high. It is dangerous and will not improve cleaning of the barrels.

Raising the board preheat temperature may increase the effectiveness of the air cleaning procedure.

For large or low melt plastic devices it is important to apply even removal force when lifting the device from the board. Two tools/hands may be required. Tools which apply uniform pressure, no pinch points, will be most effective for low melt plastic devices.

It may be required to use a secondary operation to clean 100% of the board barrels. A vacuum desoldering hand tool and/or solder wick can be used for most applications.

In the automatic mode the end of solder flow is indicated by an audible signal. Do not attempt to remove component after the signal.

The board must remain rigid and level during the removal process. Do not pull the board upward away from the wave or push downward into the wave since this will cause flooding. Fixturing may be required.

4.15 Component Replacement

Reference Soldering procedure.

4.15.1 Automatic Method

After the holes have been cleaned, flux the leads and bottom of the board.

Follow Soldering procedure.

4.15.2 Manual Method

It is possible to insert a replacement component during the removal process while the solder is flowing.

If the operator has sufficient skill, the component can be easily positioned, inserted without bending leads and solder quality can result then the following method may be used.

After the component is sufficiently removed and with the component leads fluxed and possibly preheated, the replacement component is inserted with solder flowing.

The cycle is stopped by the footswitch after sufficient reflow or carrier may be raised to enhance solder peeling.

5: Maintenance/Parts

5	<i>Maintenance/Parts</i>	3
5.0	Preventative Maintenance Schedule	3
5.1	Solder Removal	4
5.2	Pump Cleaning	4
5.3	Pump Disassembly & Cleaning	5
5.4	Pump Leveling	8
5.5	PCBRM System 5.2 – Specific Parts	11
5.6	PCBRM15 - Mechanical Breakdown	12
5.7	PCBRM15 -Electrical Compartment	14
5.8	PCBRM15 - Fuses	15
5.9	Tooling	16

5 Maintenance/Parts

5.0 Preventative Maintenance Schedule

CAUTION:

ALL SAFETY PRACTICES MUST BE OBSERVED.

Daily:

- **Clean exterior of machine to rid of solder deposits, flux, and dirt.**
 - Use household cleaners like “409”.
 - For non-water soluble dirt (flux) use mineral spirits.

Note:

WHEN CLEANING BE CAUTIOUS OF PAINTED SURFACES, LABELS, OR PLASTIC (SWITCHES)- PROLONGED CONTACT OF SOLVENTS WILL ATTACK SURFACE.

- **Remove dross from flow well and pot cover.** The inherent nature of solder generates dross as a by-product which must be removed periodically depending on the module usage and in-house criteria. Dross removal can be accomplished only when solder is molten.
- **Remove dross from top of solder bath.** Remove dross from around impeller shaft. A fine black powder will collect at the surface where the rotating impeller shaft enters the molten solder. Remove with spatula tool. Dispose of dross in a metal container. The dross is at a very high temperature and should not contact anything that can melt or catch fire.
- **Report any problem to supervisor.** Fix any problems before further damage to the machine or customer assemblies occur.

Weekly:

- **Apply film of oil on all surfaces which solder may fall (except pot cover).** Apply 3 in 1 household oil to metal surfaces (around solder pot area) to inhibit solder and flux from permanently sticking to them. Remove side shields to get access.

Note:

SOLDER POT MUST NOT BE HEATED.

- **Apply oil to board carrier.** To protect from rusting apply oil to rails and arms of carrier. If rust appears, it can be removed with WD40 and fine emery cloth or scotch brite pads.

Note:

THE CARRIER RAIL IS SUSCEPTIBLE TO THE ENVIRONMENT. IT IS STRONGLY RECOMMENDED TO CLEAN AND OIL CARRIER FREQUENTLY.

- **Add Solder (as required).**

5.1 Solder Removal

- Use Solder Bailer to transfer solder to a container with a capacity of 150 cubic inches or more. Most of the solder can be removed with the bailer. Weight of solder is 35 lbs.

CAUTION!!

SOLDER IS HOT. USE EXTREME CAUTION.

5.2 Pump Cleaning

Pump bracket, housing, impeller and shaft are all rugged, stainless steel. The pump bearings are lubricated with high temperature grease. Heat is not the main reason for their failure – rather it is dirt (dross, flux).

Note:

WHEN REMOVING PUMP FOR CLEANING, SOLDER MUST BE REMOVED FROM POT.

To Clean Pump

1. Hold pump in a vise for disassembly.
2. Do not remove leveling screws.
3. Clean all parts (except pump bearings) thoroughly:
 - Use mineral spirits to remove dirt.
 - Use a wire brush for easy to get at areas.
 - Use a scraping tool for hard to reach areas.
4. Inspect parts before reassembling (especially pump bearings). Check bearings for free, smooth action – no binding or rough action, if so, replace.

Assembly (see Disassembly Procedure)

5. Be certain when assembling the pump housing to pump bracket that the alignment guides are lined up exactly. This will insure that the pump is level when installed back onto the machine. If they are not lined up or if the leveling screws were removed, the result will be an un-level solder wave and very poor soldering or desoldering processes.
6. Spin pump shaft to be certain that the pump is assembled correctly before placing back on machine.

Note:

ONCE PUMP IS INSTALLED ONTO THE MACHINE, CHECK THE LEVEL OF THE PUMP. IF ADJUSTMENT IS NEEDED, REFER TO PUMP LEVELING PROCEDURE.

5.3 Pump Disassembly & Cleaning

CAUTION

SOLDER WILL BE HOT

7. Remove Pump Baffle (P) using needle nose pliers while pump is in the pot with solder.
8. Remove solder from pot using ladle supplied with unit.

Note

ALLOW MACHINE TO COOL BEFORE REMOVING PUMP FROM POT.

9. Remove two screws holding pulley guard to pump.
10. Remove two screws holding pump to pot.
11. Remove two screws holding pump housing (B) to pump bracket (A) and remove housing (B).

Note

DO NOT LOOSEN OR REMOVE THE FOUR LEVELING NUTS (L) AND SET SCREWS (M) OR THE PUMP WILL NEED TO BE RE-LEVELLED UPON INSTALLATION.

12. Loosen the two set screws on the pump pulley (G).
13. Remove the two bearing retaining screws (H) and washer (I).
14. Slide the pump shaft (D) with impeller (C) out of the pump bracket (A). Pump sleeve (N) will drop away at this point.
15. Remove pump bearings (E), spacer (F) and pulley (G) from pump bracket (A).

Note

INSPECT BEARINGS FOR SMOOTH MOVEMENT. REPLACE IF NECESSARY.

16. Remove pump shaft (D) from impeller (C) and discard.
17. Remove pump sleeve insert (R) and discard.
18. Clean all parts of solder and dirt using a wire brush or a tool to scrape solder from pieces.
19. Re-assemble pump as shown in drawing as follows:
 - Insert lower bearing into pump bracket.
 - Turn bracket upside down and insert pulley (hub side) into upper bearing hole.
 - Place spacer on top of pulley.
 - Insert shaft into bracket, through pump sleeve, bearing spacer and pulley.
 - Turn bracket over and insert upper bearing.
 - Install bearing retaining screws (H) and (I).
 - Tighten pulley set screws.
 - Install impeller onto shaft – before tightening the set screw be certain the play from the shaft and bearings will not cause impeller to hit pump bracket face. Allow for this clearance before tightening set screw.
 - Spin shaft with fingers and check for any interference. Correct as required.
 - Install pump housing (B) to bracket (A). Be certain the index marks are aligned exactly before tightening. If they are not, the pump will not be level.
 - Spin shaft with fingers and check for any interference between impeller and housing.
20. Pump is now ready for installation back into pot. Use anti-seize on the mounting screws when installing. Alternate tightening screws until snug. DO NOT OVERTIGHTEN. Over-tightening could cause pump to become un-level.
21. Check level of pump to carrier arms. Re-level if required.

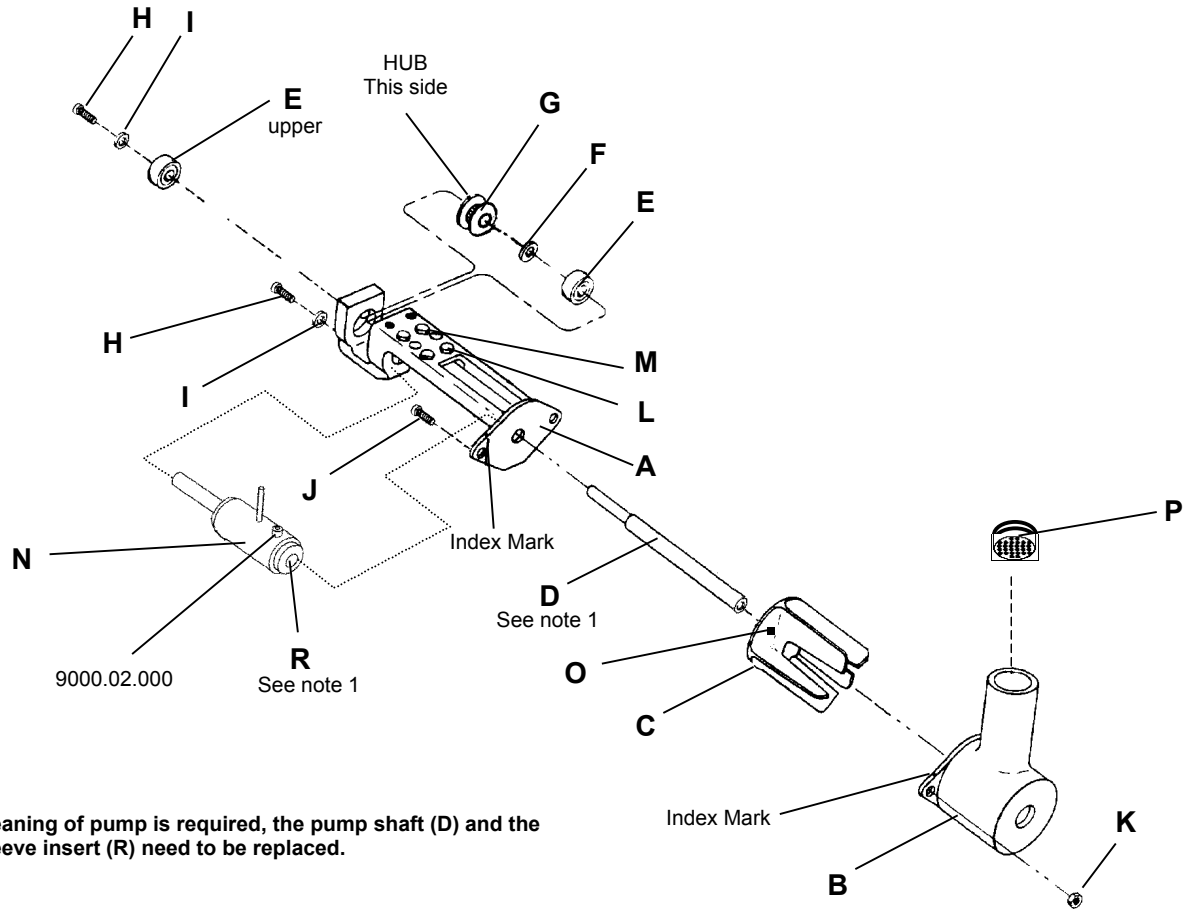

NOTE 1:
 When cleaning of pump is required, the pump shaft (D) and the pump sleeve insert (R) need to be replaced.

Item	Description	Qty.	Part# (PCBRM15)
-	Pump Assembly-PCBRM15	1	2004.01.044
A	Pump Bracket	1	2004.01.102 (gray iron)
B	Pump Housing	1	2004.01.101 (gray iron)
C	Pump Impeller	1	2004.01.100 (gray iron)
D	Shaft	1	2004.01.103 (titanium)
E	Bearing	2	9001.09.020
F	Spacer	1	12464
G	Pulley	1	12453
H	Screw, 6-32 x 1/4 Button Hd	2	60A
I	Washer, #6 SAE	2	9A
J	Screw, 10-32 x 5/8	2	9000.00.000 (titanium)
K	Nut, 10-32	2	9000.06.002 (titanium)
L	Nut, 6-32 x	4	8B
M	Set Screw, 6-32 x 5/16	4	11A
N	Pump Sleeve Assembly	1	2004.01.041 (titanium)
O	Set Screw, 10-32 x 3/8	1	9000.10.249 (titanium)
P	Baffle Assembly	1	2004.01.043 (titanium)
Q	Pump Mounting screws (10-32 x _)	2	23A
R	Pump Insert	1	12418

5.3.1 Replacement of Pump Bearings:

- Follow all the steps outlined in **Pump Disassembly**.
- After Impeller and Shaft Assembly are removed, the Impeller Pulley, Bearing Spacer, and Lower Bearing can be removed.
- Remove Bearing Retainer Hex Screw and Washer, allowing removal of Upper Bearing.
- Use graphite lubricant on screws.

5.3.2 Replacement of Drive Belt (A):

- Disconnect electrical power.
- Remove Rear Cover Screws (4).
- Remove Flow Well (B) & Pot Cover (C).
- Remove Belt Guard Hex Screws (2) and Belt Guard (D).
- Loosen Screws (4) holding Motor (E). Slide motor as high as possible.
- Remove Drive Belt (A).
- Replace Drive Belt and reassemble.

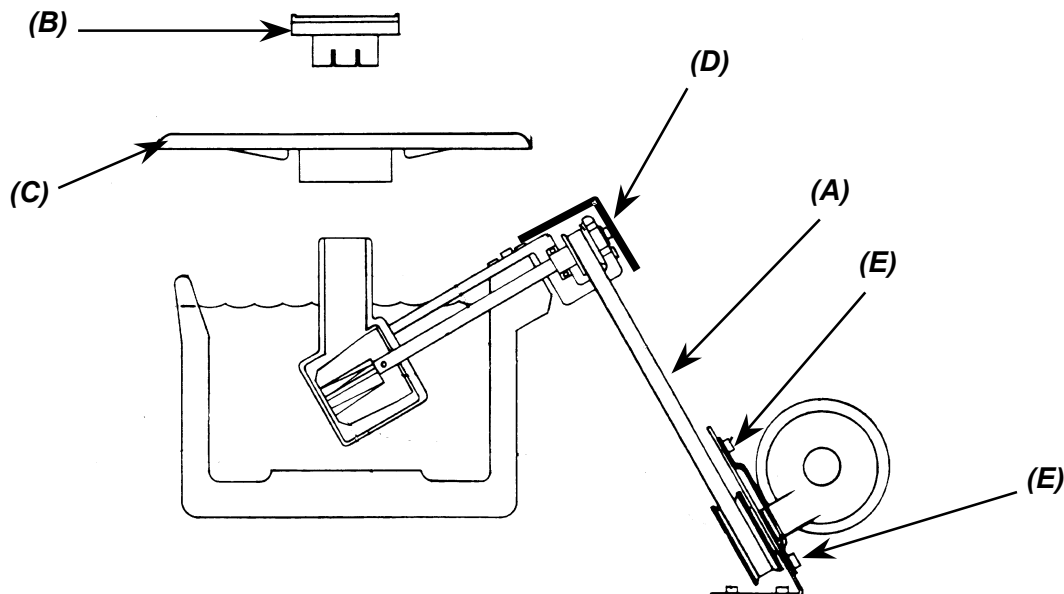

5.4 Pump Leveling

Carrier Arms Parallel Solder Pump:

Tools Needed:

- 1/16" Allen wrench,
- 5/16" Crescent wrench,
- Bubble level

Steps:

- Mount the pump onto the solder pot and snug the mounting screws. **DO NOT OVER TIGHTEN.**
- Bring to bear the (4) leveling screws leaving the lock nuts loose.

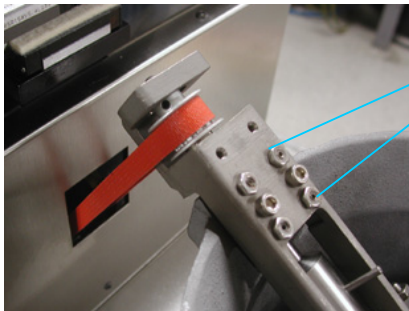

Right two leveling screws and lock nuts

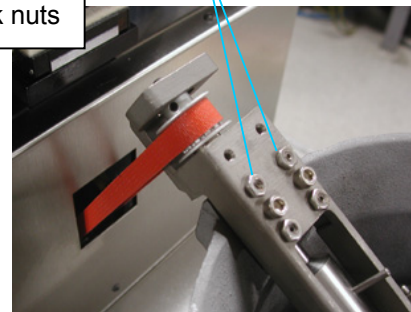

Top two leveling screws and lock nuts

Note:

WHEN ADJUSTING THE PUMP, THE TWO MOUNTING SCREWS NEED TO BE LOOSENED PRIOR TO MAKING ADJUSTMENTS TO ANY OF THE LEVELING SCREWS. THEN, SNUG BACK DOWN TO READ THE LEVEL. TWO LEVELING SCREWS NEED TO BE ADJUSTED IN ANY ONE ADJUSTMENT.

EXAMPLE – WHEN PARALLELING THE PUMP TO THE CARRIER ARMS, EITHER THE RIGHT TWO SCREWS WILL BE ADJUSTED TOGETHER, OR THE LEFT TWO SCREWS TOGETHER FOR EAST/WEST ADJUSTMENT. AND THE BOTTOM TWO SCREWS WILL BE ADJUSTED TOGETHER OR THE TOP TWO SCREWS FOR NORTH/SOUTH ADJUSTMENT IT IS ALSO VERY CRITICAL TO ADJUST BOTH SCREWS EXACTLY THE SAME AMOUNT.

- Locate the level in the carrier arm as if it were a PCB. Note the position of the bubble. Place the level on the pump housing stack the same way. Note the difference between the two bubbles. Determine which two leveling screws will need to be adjusted and by how much.

Note: THE PUMP HOUSING STACK MUST BE PARALLEL TO THE CARRIER ARMS. THEY DO NOT NEED TO BE LEVEL. LEVELING THE MACHINE IS THE NEXT STEP

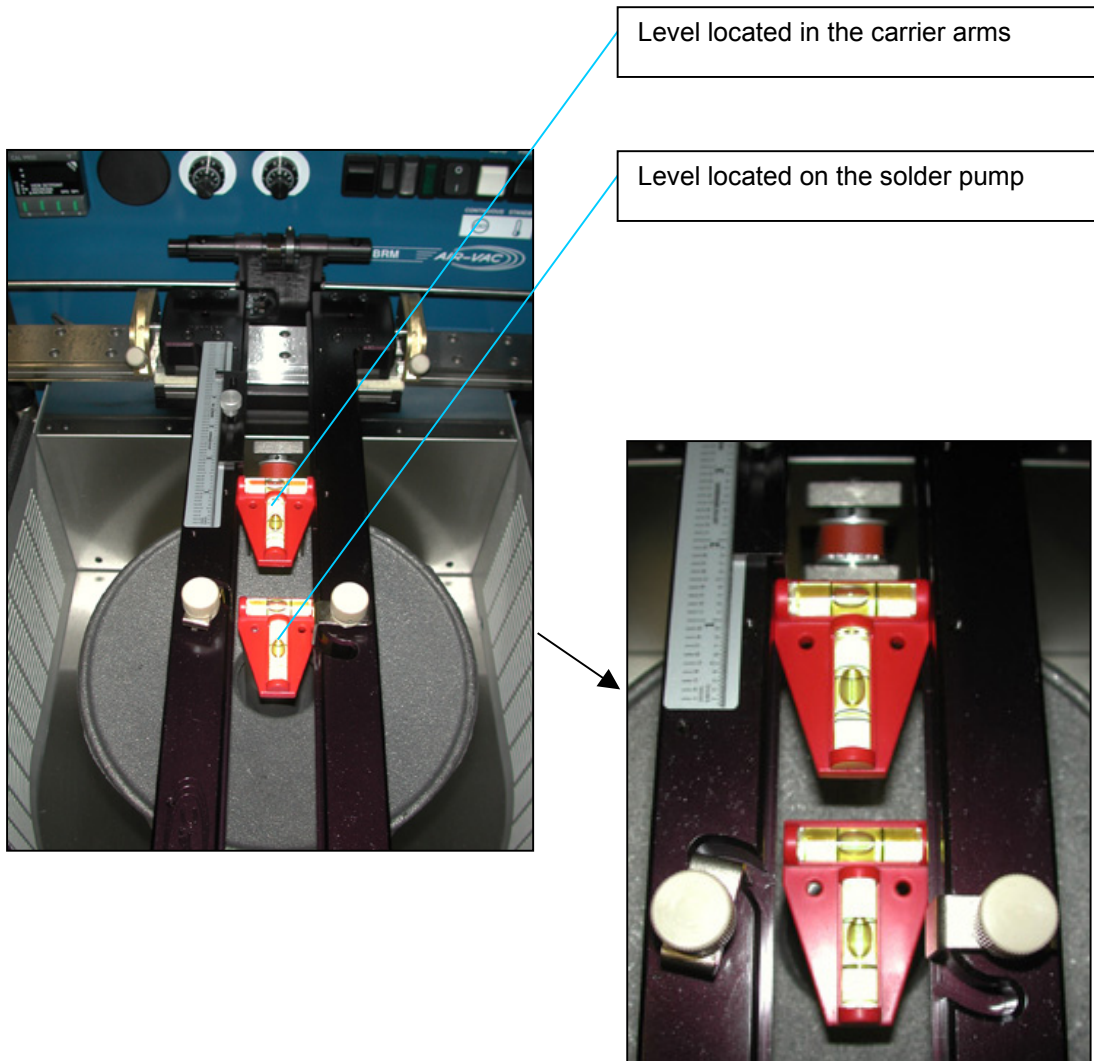

- Re-check the level of the pump and lock down the (4) lock nuts. **DO NOT OVER TIGHTEN.**

Machine Level:

- Next **level the machine**, place level on the solder pump and level the machine on a workbench. Bring the bubble dead center in both x and y positions by using the machine legs. Once level has been achieved, lock legs in place with jam nut.

- Install motor belt to pump and motor. Apply downward pressure on motor to achieve belt. Tension and tighten motor screws.

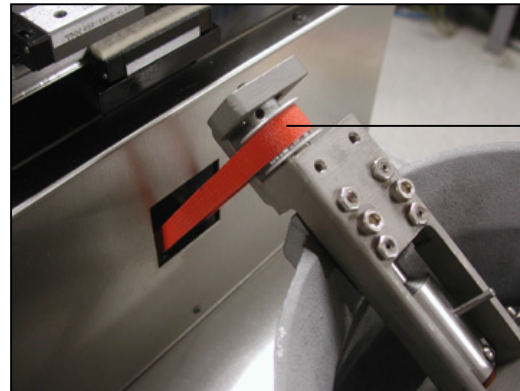

Motor belt

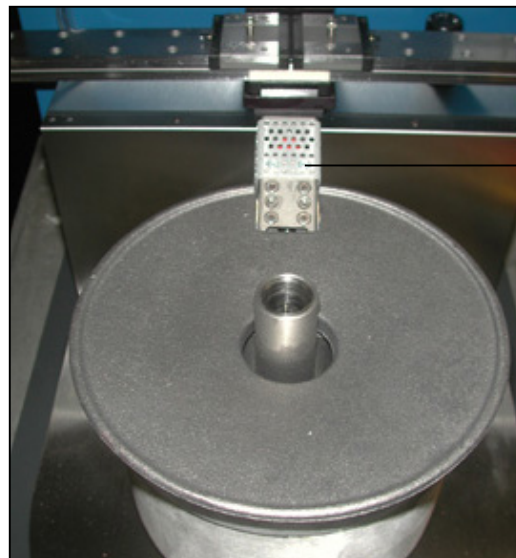

Pulley guard

- Attach pulley guard (2) 1/4 hex head screws.
- Install pot heat shield.
- Install rear door.
- Turn machine on and let it heat up.

Note: **Do not run pump without solder. Damage to the pump sleeve will occur!**

- Once machine comes up to temperature, load **lead free** solder (approx. 35 lbs), _" from top of pot.
- Once pot is filled with solder, place pot cover on pot.

5.5 PCBRM System 5.2 – Specific Parts

Note

SEE PCBRM15 FOR A LIST OF COMMON PARTS.



Item	Part#	Description
1		Temperature Controller
2	PH161	Circuit Breaker
3	Proj.DRS.SCS.73	Handle
4	4005.01.111	Handle Extension
5	ST350	Flow Well Heater Box (option)
6	PH154	Panel Heater
*	PH157	Panel Heater Thermocouple (not shown)

5.6 PCBRM15 - Mechanical Breakdown

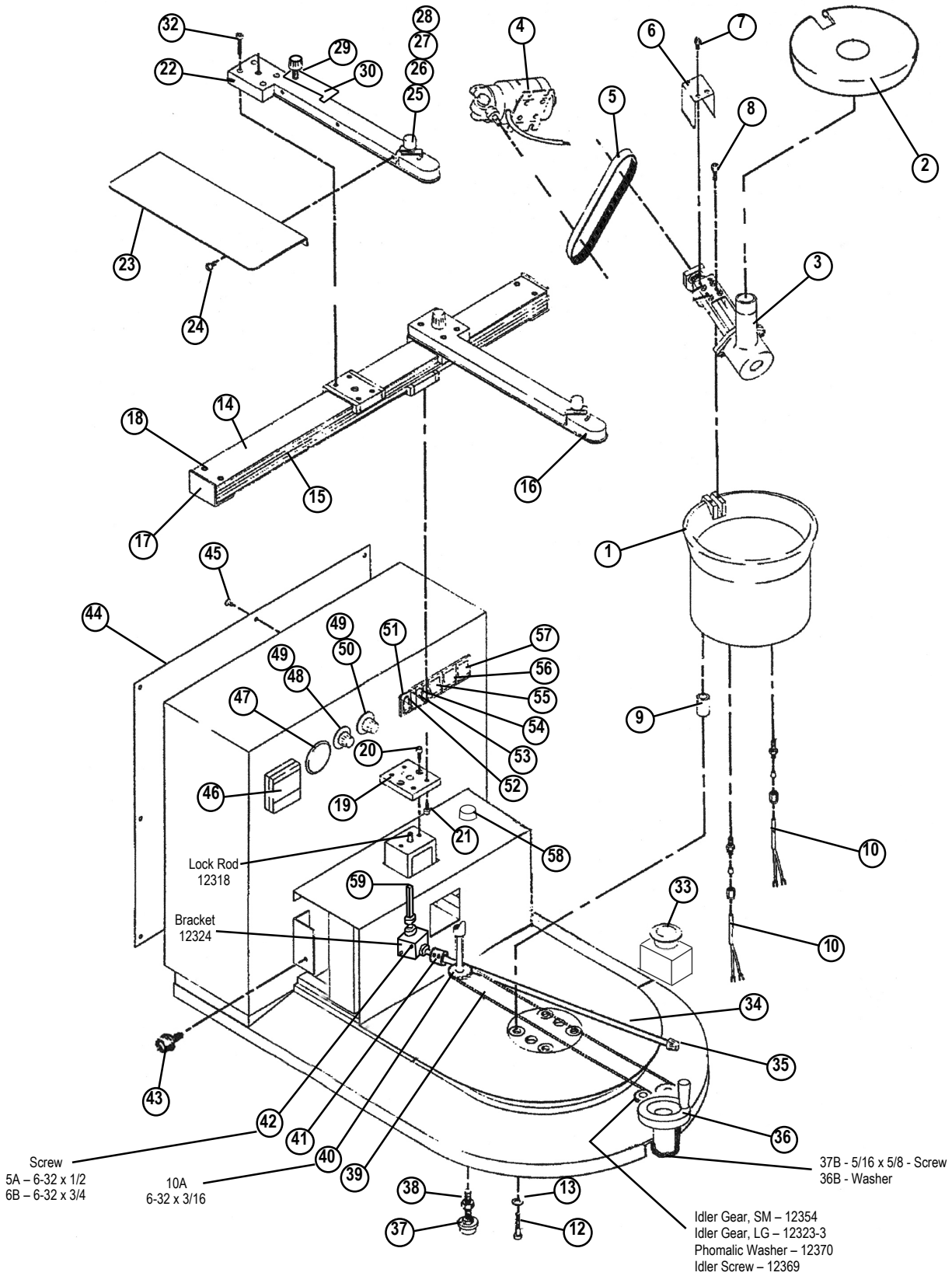

Mechanical Breakdown - Parts List

	<u>Description</u>	<u>Qty.</u>	<u>Part Number</u>
1.	Solder Pot	1	12510
2.	Solder Pot Cover	1	2004.01.108
3.	Pump Assembly, only	1	2004.01.040
4.	Motor Assembly	1	12420
5.	Drive Belt - High Temperature	1	12467
6.	Belt Guard	1	12461
7.	Belt Guard Hex Screw	2	59A
8.	Pump Mounting Screw	2	23A
9.	Pot Spacer	4	12511
10.	Thermocouple/Process with fitting	2	12801
12.	Pot Screw	4	21A
13.	Washer, Pot Screw	4	33A
14.	Upper Carrier Rail	1	12365
15.	Lower Carrier Rail	1	12366
16.	Right Carrier Arm Assembly	1	12305
17.	Rail Stop	2	12315
18.	Screw, 6-32 x 3/4, Rail Stop	4	6B
19.	Adaptor Plate	1	12325
20.	Adapter Screw	2	22A
21.	Carrier Attach Screw	8	30A
22.	Left Carrier Arm Assembly	1	12304
23.	Heat Shield	1	12322
24.	Screw, 6-32 x 1/4, Heat Shield	3	1A
25.	Bracket	1	12316
26.	Spring	1	12374
27.	Knob	1	12319-1
28.	Washer, #10	1	53A
29.	Y-Stop Knob	1	0100.03.046
30.	Y-Stop	1	12326
31.	Carrier Arm, Lock Knob	2	12306
32.	Arm Attach Screw	4	29B
33.	E-Stop	1	12837
34.	Carrier Lock Shaft	1	12320
35.	Carrier Lock Knob	1	12356
36.	Z-Crank Assembly	1	12CK
37.	Leveling Legs	4	12151
38.	Hex Nut, 5/16	1	36A
39.	Height Adjustment Belt	1	12CK6
40.	Drive Rod Gear	1	12353
41.	Coupling	1	12362
42.	Gear Box	1	12358
43.	Pot Shield Knob	2	12308
44.	Rear Panel	1	12812
45.	Rear Panel Screw	8	13B
46.	Temperature Controller - Watlow	1	9002.11.057
47.	Air Gauge	1	12757
48.	Flow Potentiometer - 50k	1	9002.05.018
49.	Knob and Dial	2	9002.18.001
50.	Duration Potentiometer - 25k	1	9002.05.017
51.	Power Switch	1	12856
52.	Reset Switch	1	12853-2
53.	Power Light	1	12877-Z
54.	Cycle Light	1	12876
55.	Cycle Switch	1	12854
56.	Mode Switch	1	12855
57.	Temp Switch/Power	1	12856
58.	Air Regulator	1	9001.12.006
59.	Drive Shaft	1	12359

5.7 PCBRM15 -Electrical Compartment

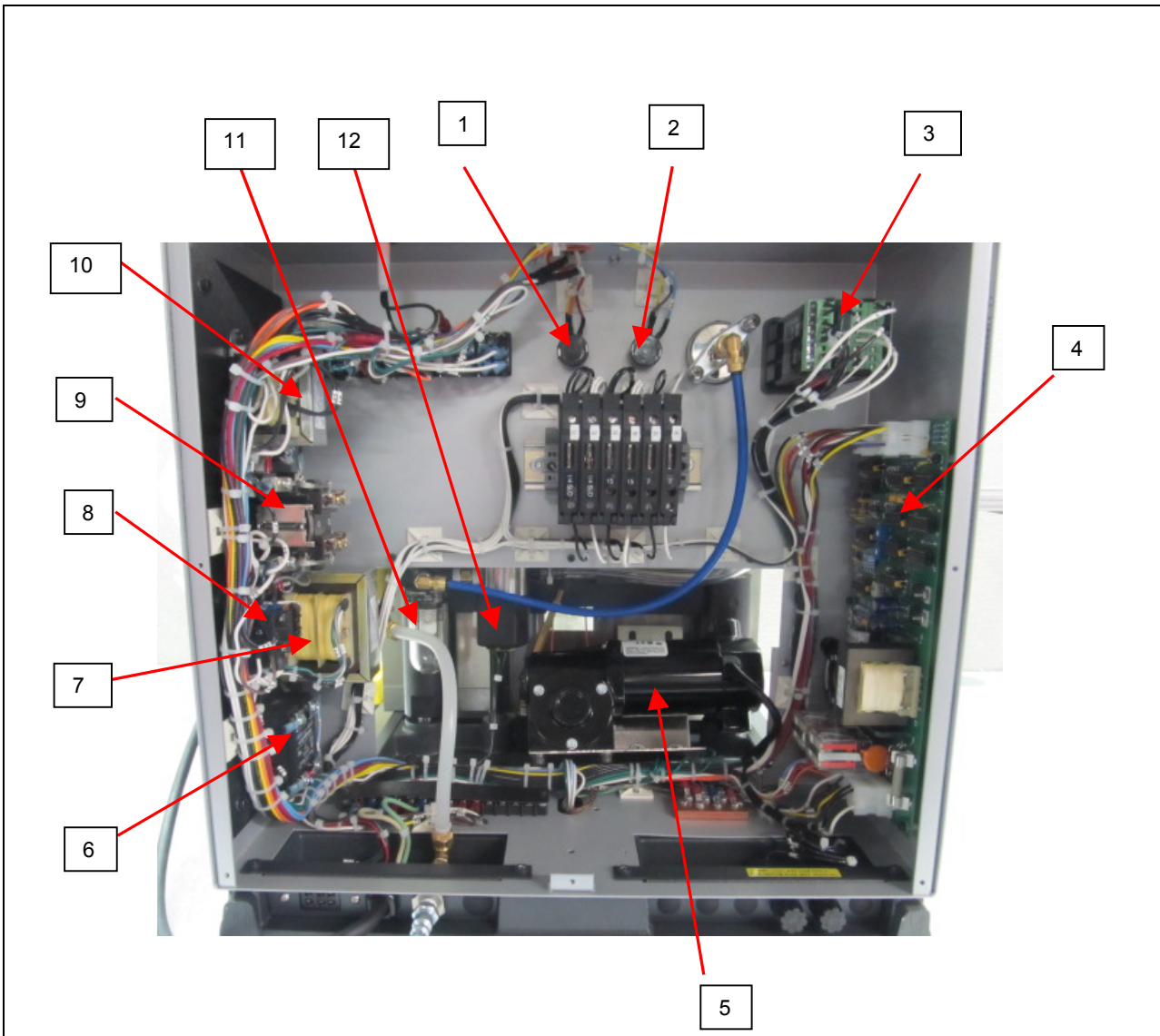

- 1. 9002.05.017 Potentiometer duration, 25K
- 2. 9002.05.018 Potentiometer flow, 50K
- 3. 9002.11.051 Temperature controller (Watlow)
- 4. 12862 Cycle control board
- 5. 12420 Motor assembly
- 6. 12865 Pot relay
- 7. 12864 Transformer 220/110v
- 8. 12879 Latching relay 24v
- 9. 12883 Emergency off relay 24v
- 10. 12882 Transformer 220/24v
- 11. 9001.12.006 Air regulator
- 12. 12750 Solenoid

5.8 PCBRM15 - Fuses

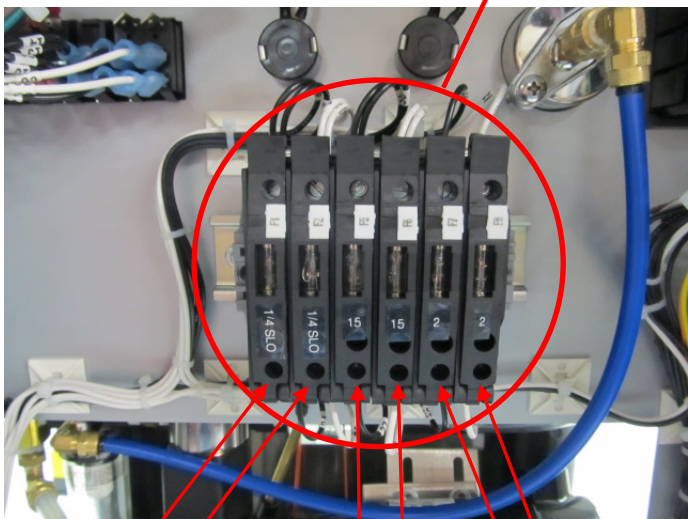
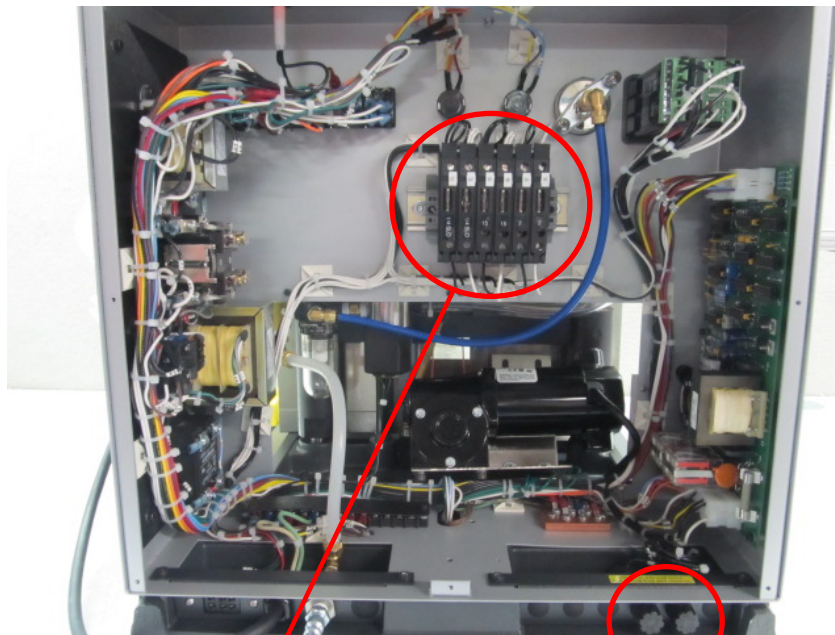

1/4 AMP Slow-Blow

15 AMP

2 AMP

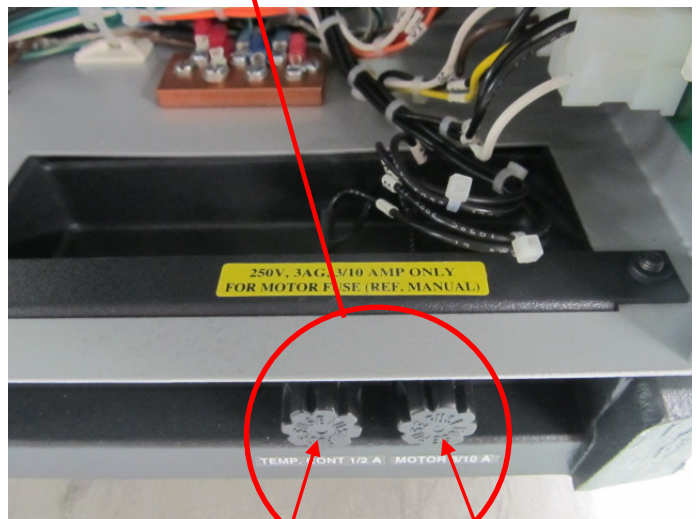

1/2 AMP Slow-Blow

3/10 AMP

NOTE: Refer to the schematic # 2004.00.902

5.9 Tooling

5.9.1 Special Soldering/Desoldering Applications

- Special Flow Wells and Cleaning Hoods can be manufactured for specific applications where issues of clearance, adjacent components and mixed technology boards are concerns.
- Consult Air-Vac for details concerning your specific requirements and the optimum solution.
- A detailed dimensioned customer print and sample of the assembly are critical to design.

Flow Wells determine the size, shape and direction of the solder wave:

- Bottom side critical areas must be addressed. Edge distances (A) and height of bottom side components (B) must be known.

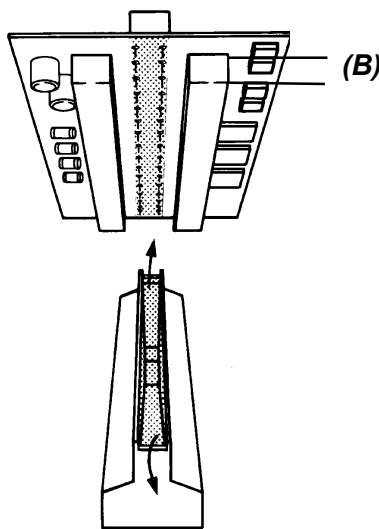

For double-sided boards, solder flow is directed away from adjacent bottom-side components.

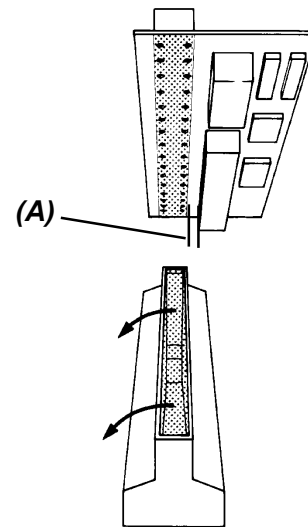

For edge connectors, solder flows away from the board.

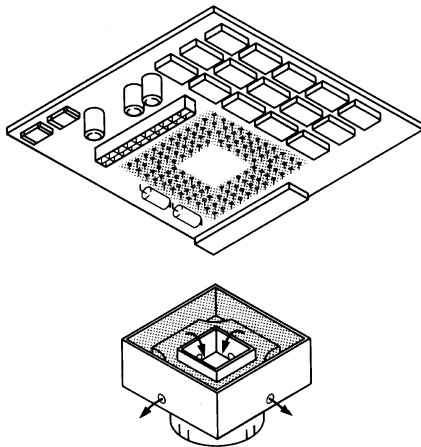

The solder flow can be directed inward, Protecting components near the lead pattern and limiting heat to adjacent area or components.

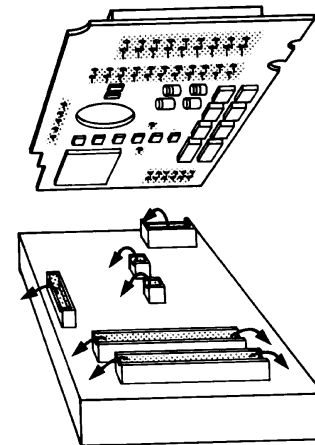

The solder flow can be directed to large select areas for multiple soldering of components.

5.9.2 Application Specific Tooling Provides the Most Efficient Process Solution

Send your board to Air-Vac for quick assistance to enhance your process and improve productivity. A three-dimensional tooling model can be forwarded to you for viewing.

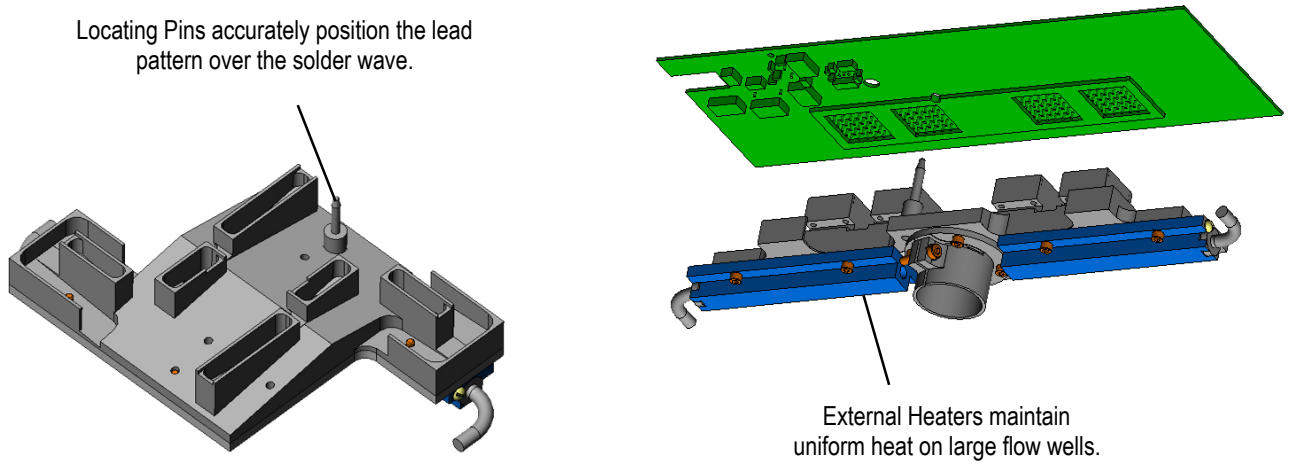

Fixtures allow multiple boards or areas to be soldered in one cycle using the y-axis stop. All boards are preheated at the same time. Fixtures can also be used to hold irregular shaped boards or support flexible assemblies.

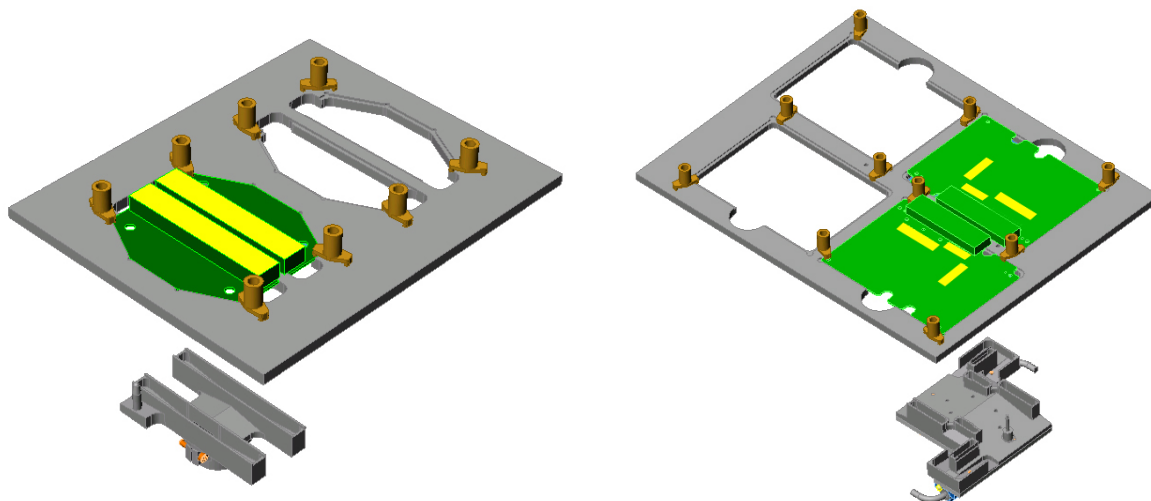

5.9.3 Standard Flow Wells & Air Cleaning Hoods

The flow well must be larger than the component lead pattern to insure that all leads are within the solder wave. Generally an edge distance of 1/16" is added around the lead pattern and on long connectors where heat dissipates at the end of the well, an edge distance of 3/16" is recommended.

Note:

NORMALLY CLEANING HOOD DIMENSIONS ARE THE SAME AS FLOW WELL DIMENSIONS. WHERE DENSITY AND/OR ADJACENT COMPONENT CONFIGURATIONS PRESENT AN INTERFERENCE PROBLEM, HOODS CAN BE MODIFIED TO MORE CLOSELY CONFORM TO LEAD PATTERNS.

Dimension (W" x L")	Flow Well Part Number	Dimension (W" x L")	Flow Well Part Number
1/4 x 1 1/4	FW8-40	7/8 x 1 5/8	FW28-52
3/8 x 1 3/8	FW12-44	1 x 1 7/16	FW32-46
3/8 x 2 3/16	FW12-70	1 1/8 x 1 1/8	FW36-36
3/8 x 2 3/4	FW12-88	1 1/4 x 1 1/4	FW40-40
3/8 x 3 1/4	FW12-104	1 3/8 x 1 3/8	FW44-44
_ x 29/32	FW16-29	1 _ x 1 _	FW48-48
_ x 1	FW16-32	1 3/4 x 1 3/4	FW56-56
3/4 x 1 5/16	FW24-42	2 x 2	FW64-64
3/4 x 1 _	FW24-48	1/4 x 4	FW8-128
3/4 x 2 _	FW24-64	3/8 x 5	FW12-160
3/4 x 2 3/16	FW24-70	_ x 5	FW16-160
3/4 x 2 _	FW24-80		

Flow Well Sizing

- The size is basically determined by the component pin centerline distances.
- The contact area must include every lead of the pattern to be contacted by flowing solder. The length and width dimensions must provide generous heat contact and ease for operator component positioning.

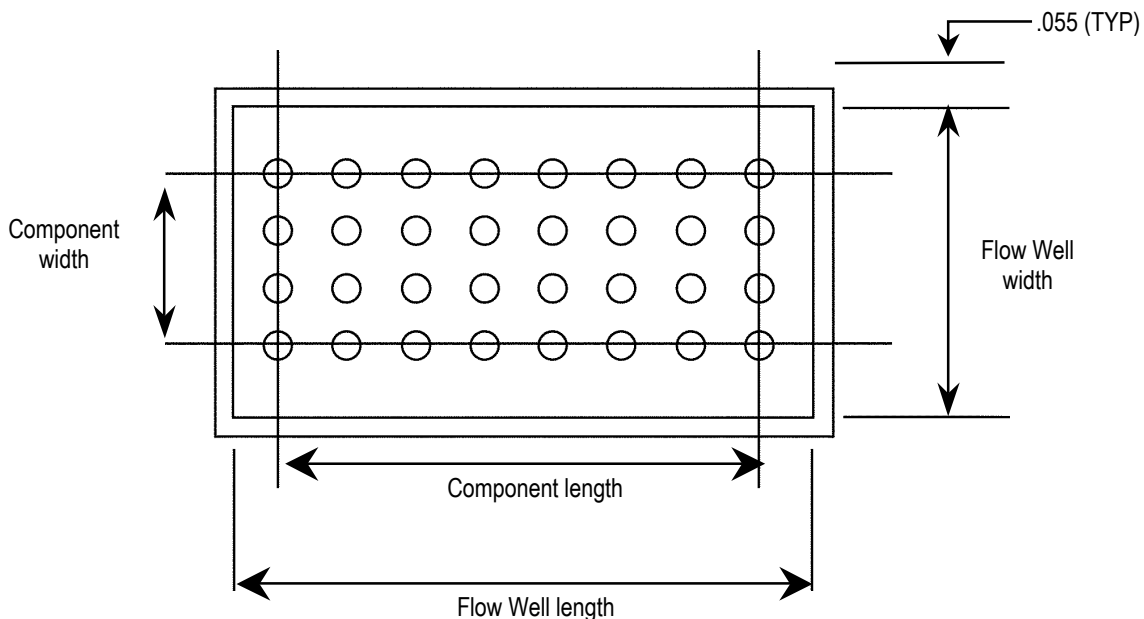

6: Troubleshooting

6	<i>Troubleshooting</i>	3
6.0	Air-Vac Technical Service	3
6.1	Common Problems/Solutions	3
6.2	Temperature Controller Installation (CAL 9900 only)	5

6 Troubleshooting

6.0 Air-Vac Technical Service

Air-Vac is always willing to assist our customers with any technical or operating questions. If you have any questions on machine parameters, correct nozzle requirements, options, procedures or maintenance, ***please do not hesitate to call.***

Air-Vac Engineering Company, Inc.

30 Progress Avenue • Seymour, CT 06483 • Tel: 203-888-9900 • Fax: 203-888-1145

www.air-vac-eng.com

e-mail:

General Sales Information: rework.sales@air-vac-eng.com

Technical Support: rework.tech@air-vac-eng.com

6.1 Common Problems/Solutions

NOTE

ALL PCBRM UNITS ARE TESTED PRIOR TO SHIPPING. TEMPERATURE CONTROLLERS ARE PROGRAMMED AND TESTED AT 500°F/260°C.

6.1.1 Machine will not turn on, or turns on for a short period and shuts off

1. Defective latching relay 12879.
2. Consult Air-Vac for further help.

6.1.2 Pump Motor will not run

1. Motor fuse blown

WARNING

DO NOT REPLACE MOTOR FUSE WITH ANY OTHER FUSE BESIDES 250V3AG, 3/10 AMP. INCORRECT FUSING CAN RESULT IN DAMAGE TO SYSTEM. IF MOTOR FUSE STARTS TO BLOW CONTINUOUSLY, SOLDER PUMP NEEDS TO BE REMOVED, DISASSEMBLED AND THOROUGHLY CLEANED.

2. Footswitch not plugged in.
3. SP2 – activated on temperature controller – see 0 #'s 3-5.
4. Stand-by switch activated.
5. Pump seized.
6. Set point temperature set too low – solder not molten.
7. Consult Air-Vac for further help.

6.1.3 Poor Solder Results

1. Un-level pump (see leveling procedure).
2. Un-level machine (see leveling procedure).
3. Z-Axis height not set correctly.
4. Baffle not being used.
5. Flow duration not set correctly.
6. Ramp up/down not set correctly.
7. Consult Air-Vac for further help.

6.1.4 Excessive Fluctuation of Solder Wave

1. Replace motor belt.
2. Motor belt tension too tight.
3. Solder pump needs to be removed from pot, disassembled and thoroughly cleaned.
4. Consult Air-Vac for further help.

6.1.5 Fault Indication (CAL9900 only)

Temperature display, on a fault indication, is replaced by "EE" flashing, followed by a digit. This indicates that an error has been detected in the system. Action should be taken as follows:

EE1 – SENSOR BURNOUT – CHECK SENSOR AND/OR CONNECTIONS THEN KEY*

EE2 – TEMPORARY SYSTEM ERROR SELF CLEANING

EE8 – LOSS OF CALIBRATION

EE9 – NVM DATA FAULT (NON VOLATILE MEMORY)

Note: Repair & Re-Calibration

DUE TO THE NATURE OF ITS DESIGN, THE 9900 CAN ONLY BE REPAIRED AND RE-CALIBRATED BY USING SPECIAL EQUIPMENT AND SHOULD BE RETURNED TO AIR-VAC IF FOUND TO BE FAULTY.

Note

TO RESET EE9 FAULT (CAUSED BY SPIKING), TURN OFF MACHINE, PRESS "P" IN AND TURN ON POWER UNTIL DISPLAY COMES ON LINE. PARAMETER LOCK NEEDS TO BE IN THE SETTING POSITION.

6.2 Temperature Controller Installation (CAL 9900 only)

1. Remove the socket by pressing in the lock buttons.
2. Slide the controller into the cut-out.
3. Fit the mounting clip by pressing it firmly against the panel, jacking screws optional.
4. Plug on the socket.

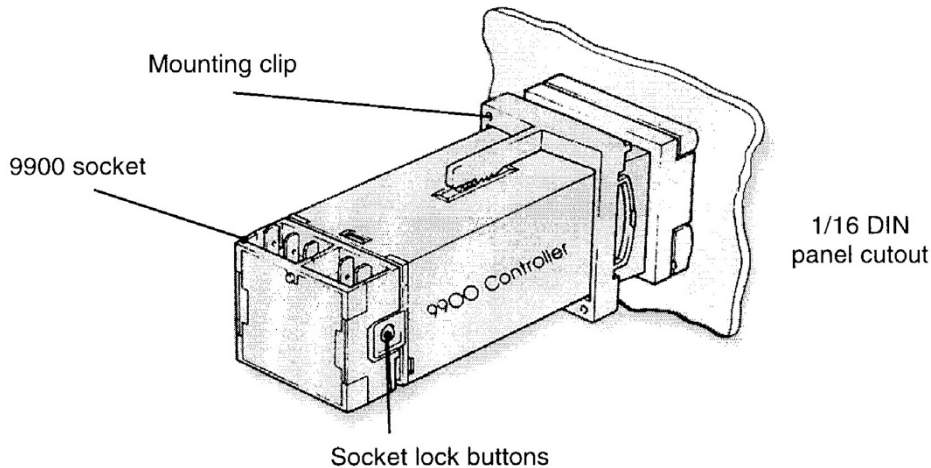

6.2.1 Setting Parameters of the CAL 9900 Temp Controller (also refer to Cal control booklet)

1. With unit ON, remove lower front panel of temperature controller. Set parameter lock to parameter setting position; white tab will need to be located on the right two pins. Replace panel.
2. PRESS "P"; right side of decimal point will be flashing.
3. Using ▼▲ buttons, program .15.
4. PRESS *, then ▼▲ buttons to reach 1.15 – Clears Unit to default settings
5. PRESS "P", display will read 0.16 -- 0. must be flashing (if 0. is not flashing, PRESS *).
6. PRESS ▼▲ to reach 1
7. PRESS * (16. must be flashing) Display should read 1.16
8. PRESS ▼▲ to reach 19 Display should read 2.19
9. PRESS *, then ▼▲ to reach 2
10. PRESS *, ▼▲ 22 Display should read 1.22
11. PRESS *, ▼▲ 1 Display should read 70.2
12. PRESS *, ▼▲ 2 Display should read 5.4
13. PRESS *, ▼▲ 70 (SP2) Display should read 6.5
14. PRESS *, ▼▲ 4 Display should read 5.6
15. PRESS *, ▼▲ 5 Display should read 5.7
16. PRESS *, ▼▲ 5 Display should read 5.6
17. PRESS *, ▼▲ 6 Display should read 5.7
18. PRESS *, ▼▲ 6 Display should read 7.8
19. PRESS *, ▼▲ 6 Display should read 7.8
20. PRESS *, ▼▲ 7
21. PRESS *, ▼▲ 5
22. PRESS *, ▼▲ 8
23. PRESS *, ▼▲ 7
24. PRESS "P"
25. To set process temperature (SP1), PRESS * and hold – at the same time PRESSING ▼▲ to desired temperature.
26. Set parameter lock to its locked position. The white tab will need to be on the left two pins.

To Check Program:	
1. PRESS "P"	
2. PRESS ▲	
Program #'s should read as follows:	
0.0	0.13
0.1	0.14
0.3	1.16
5.4	0.17
6.5	0.18
5.6	2.19
5.7	0.20
7.8	0.21
0.9	1.22
0.10	7.23
0.11	--24
0.12	0.25

7: Schematics

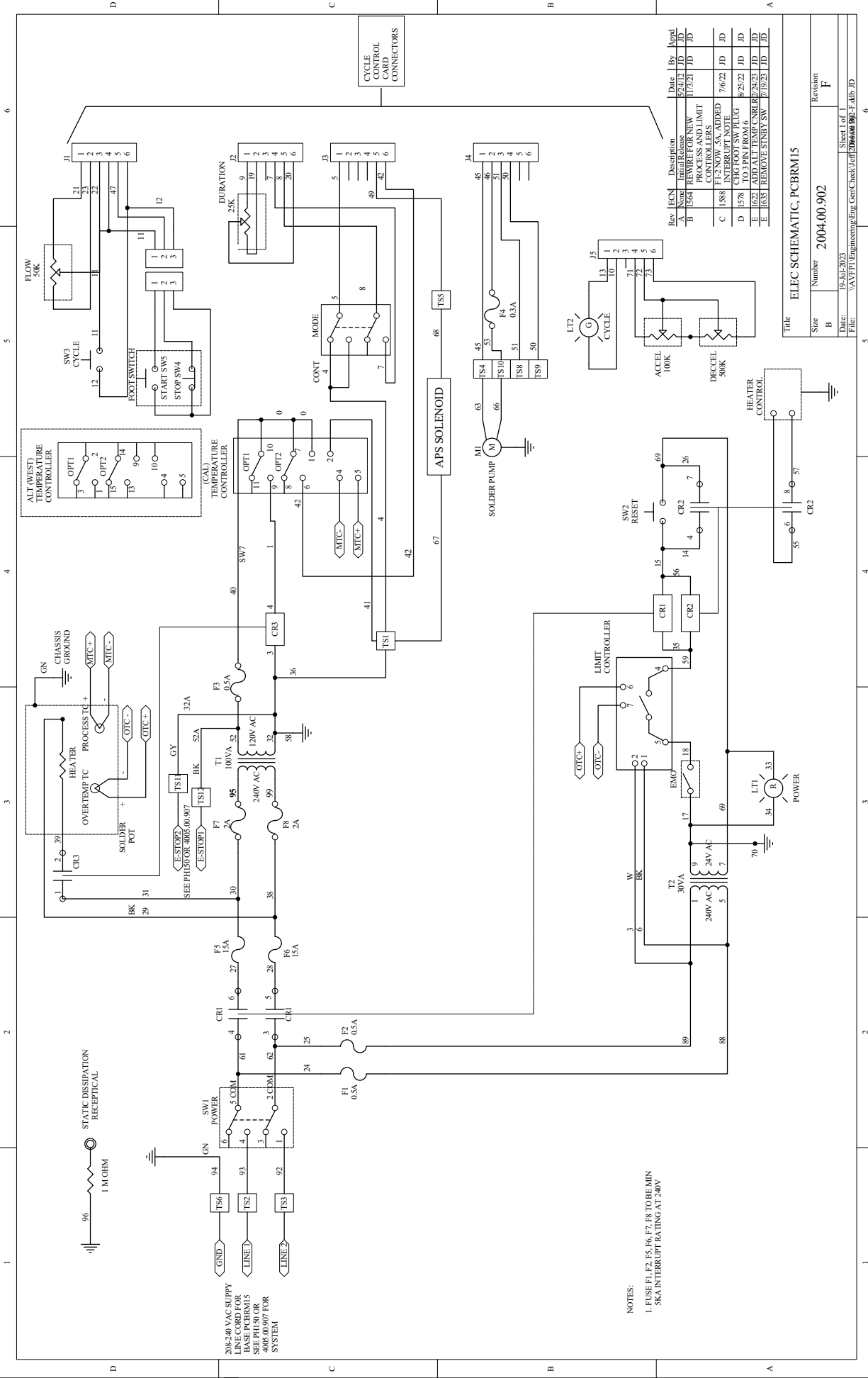

NOTES:
 1. FUSE F1, F2, F5, F6, F7, F8 TO BE MIN
 5KA INTERRUPT RATING AT 240V

Rev.	ECN	Description	Date	By	App'd
A	1564	INITIAL RELEASE	5/24/12	JD	JD
B	1564	REWIRE FOR NEW PROCESS AND LIMIT CONTROLLERS	7/6/22	JD	JD
C	1588	INTERLUPT NOTE	8/25/22	JD	JD
D	1578	CHG FOOT SW PLUG TO 3 PIN FROM 6	8/25/22	JD	JD
E	1622	ADD ALT TEMP CNTRL	8/23/23	JD	JD
F	1633	REMOVE STBY SW	7/19/23	JD	JD

Title		ELEC SCHEMATIC, PCBRM15	
Size	Number	Revision	F
B	2004.00.902		
Date:	8/14/2003	Sheet 1 of 1	
File:	\\AVFPI\Engineering\Elec_Gen\Check\cell\200400902_F.dwg		

1 2 3 4 5 6

D C B A

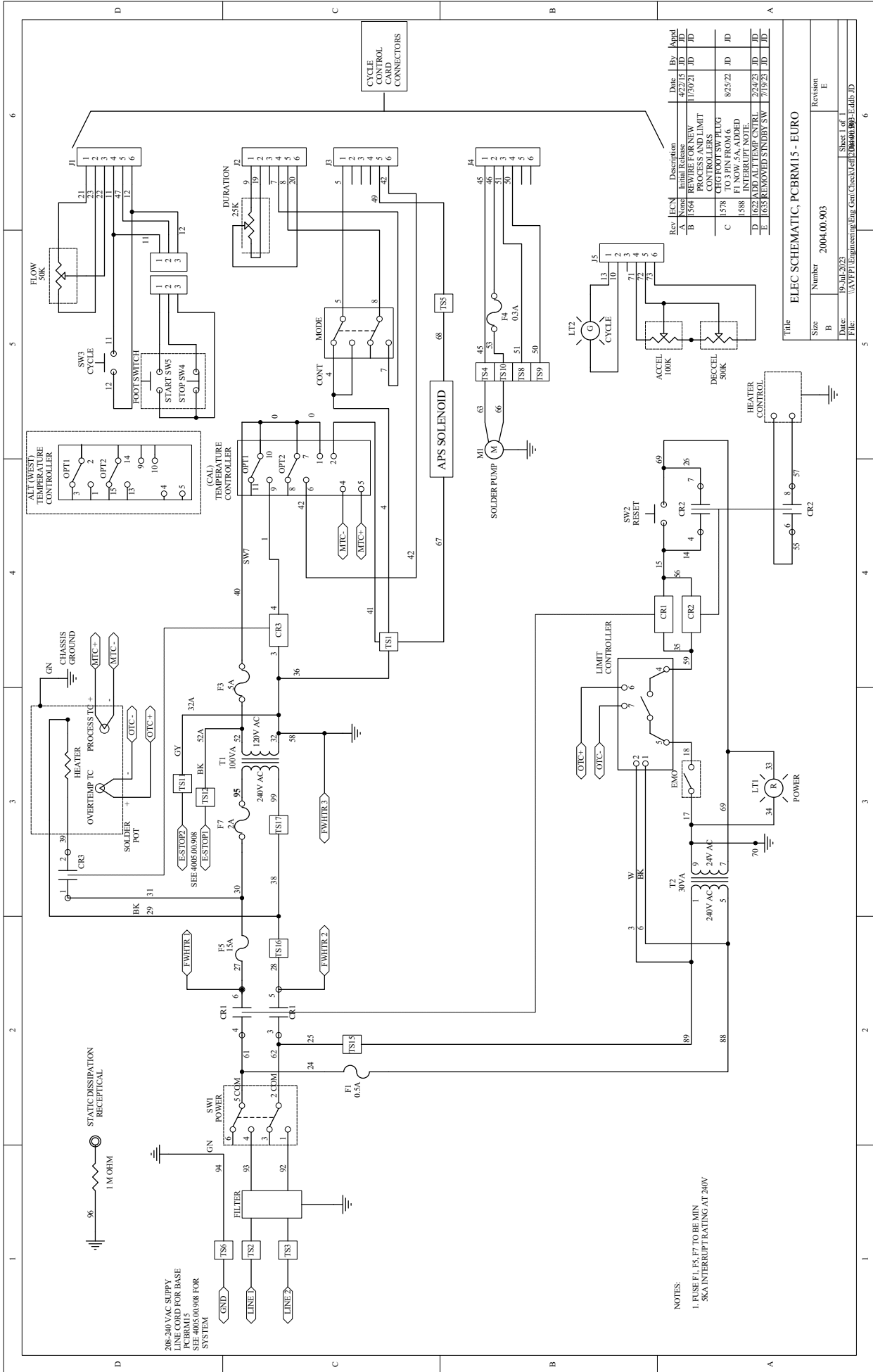

208-240VAC SUPPLY
LINE CORD FOR BASE
PCBRM15
SEE 4005/0098 FOR
SYSTEM

NOTES:
1. FUSE F1, F5, F7 TO BE MIN
5KA INTERRUPT RATING AT 240V

Rev	ECN	Description	Date	By	App'd
A	1564	INITIAL RELEASE	4/22/15	JD	JD
B	1564	REVISE FOR NEW PROCESS AND LIMIT	11/30/21	JD	JD
C	1578	CHG FOOT SW PLUG TO 3 PIN FROM 6.	8/25/22	JD	JD
D	1588	F1 NOW .5A-ADDED INTERRUPT NOTE.	2/24/23	JD	JD
E	1637	REMOVED SW11, SW12, SW13, SW14, SW15, SW16, SW17, SW18, SW19, SW20, SW21, SW22, SW23, SW24, SW25, SW26, SW27, SW28, SW29, SW30, SW31, SW32, SW33, SW34, SW35, SW36, SW37, SW38, SW39, SW40, SW41, SW42, SW43, SW44, SW45, SW46, SW47, SW48, SW49, SW50, SW51, SW52, SW53, SW54, SW55, SW56, SW57, SW58, SW59, SW60, SW61, SW62, SW63, SW64, SW65, SW66, SW67, SW68, SW69, SW70, SW71, SW72, SW73, SW74, SW75, SW76, SW77, SW78, SW79, SW80, SW81, SW82, SW83, SW84, SW85, SW86, SW87, SW88, SW89, SW90, SW91, SW92, SW93, SW94, SW95, SW96, SW97, SW98, SW99, SW100	7/19/23	JD	JD

Title		Revision	
ELEC SCHEMATIC, PCB RM15 - EURO		E	
Size	Number	Date	Sheet 1 of 1
B	2004.00.903	19-Jul-2023	1
File: \\AVI\PI\Engineering\Eng_Cent\Check\Cell\000401903-E-Add\JD			

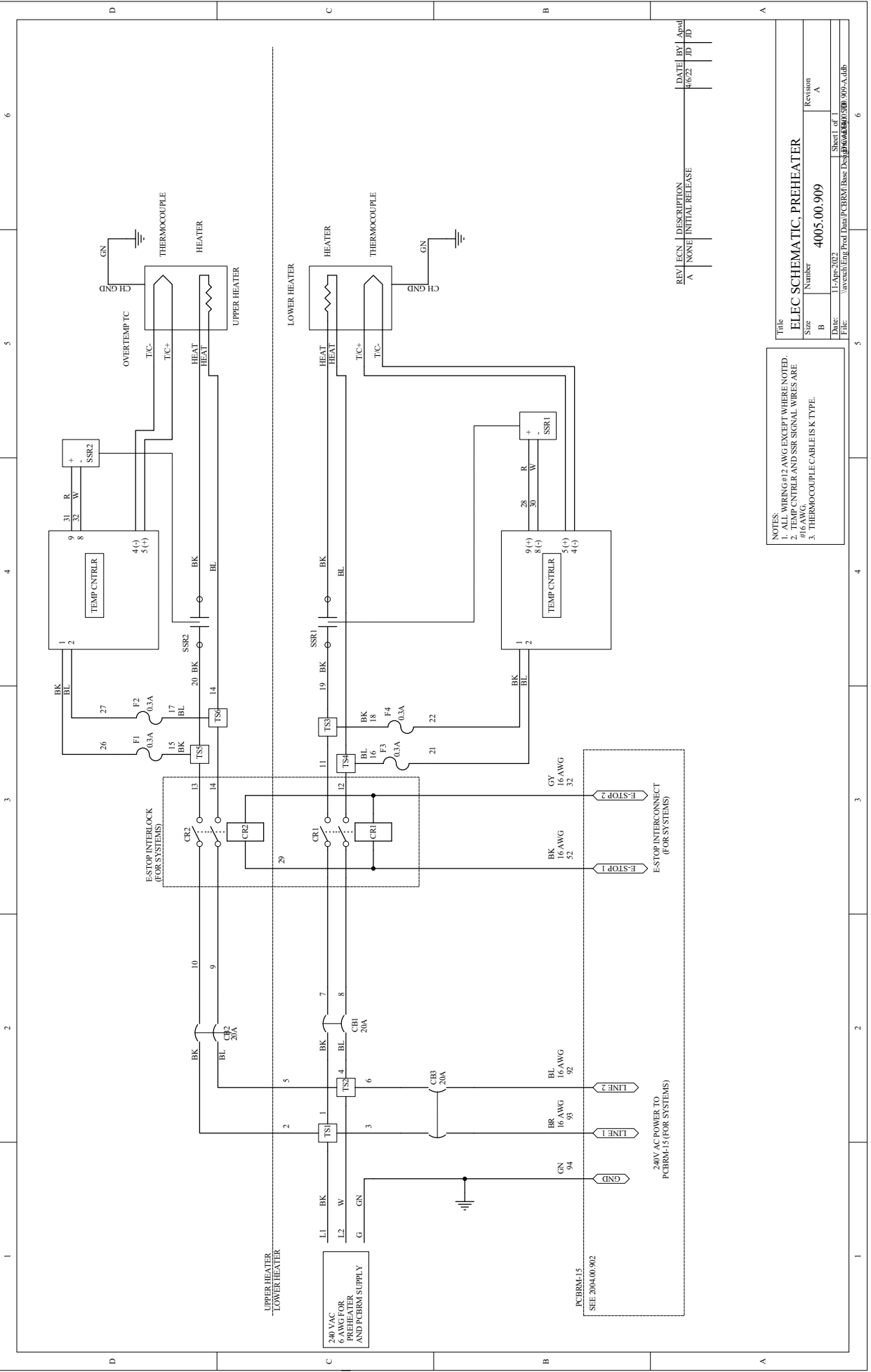

REV	ECN	DESCRIPTION	DATE	BY	APP'D
A		NONE INITIAL RELEASE	#6/22	JD	JD

Title		ELEC SCHEMATIC, PREHEATER	
Size	Number	Revision	
B	4005.00.909	A	
File	1-APP-3903	Sheet	4
File	WorkSheet/Eng Prod Data/PCBRM/Basic Des/PCBRM/4005.00.909-A.dwg		

- NOTES:
1. ALL WIRING #12 AWG EXCEPT WHERE NOTED.
 2. TEMP CNTRLR AND SSR SIGNAL WIRES ARE #16 AWG.
 3. THERMOCOUPLE CABLE IS K TYPE.

1

2

3

4

5

6

1

2

3

4

5

6

A

B

C

D

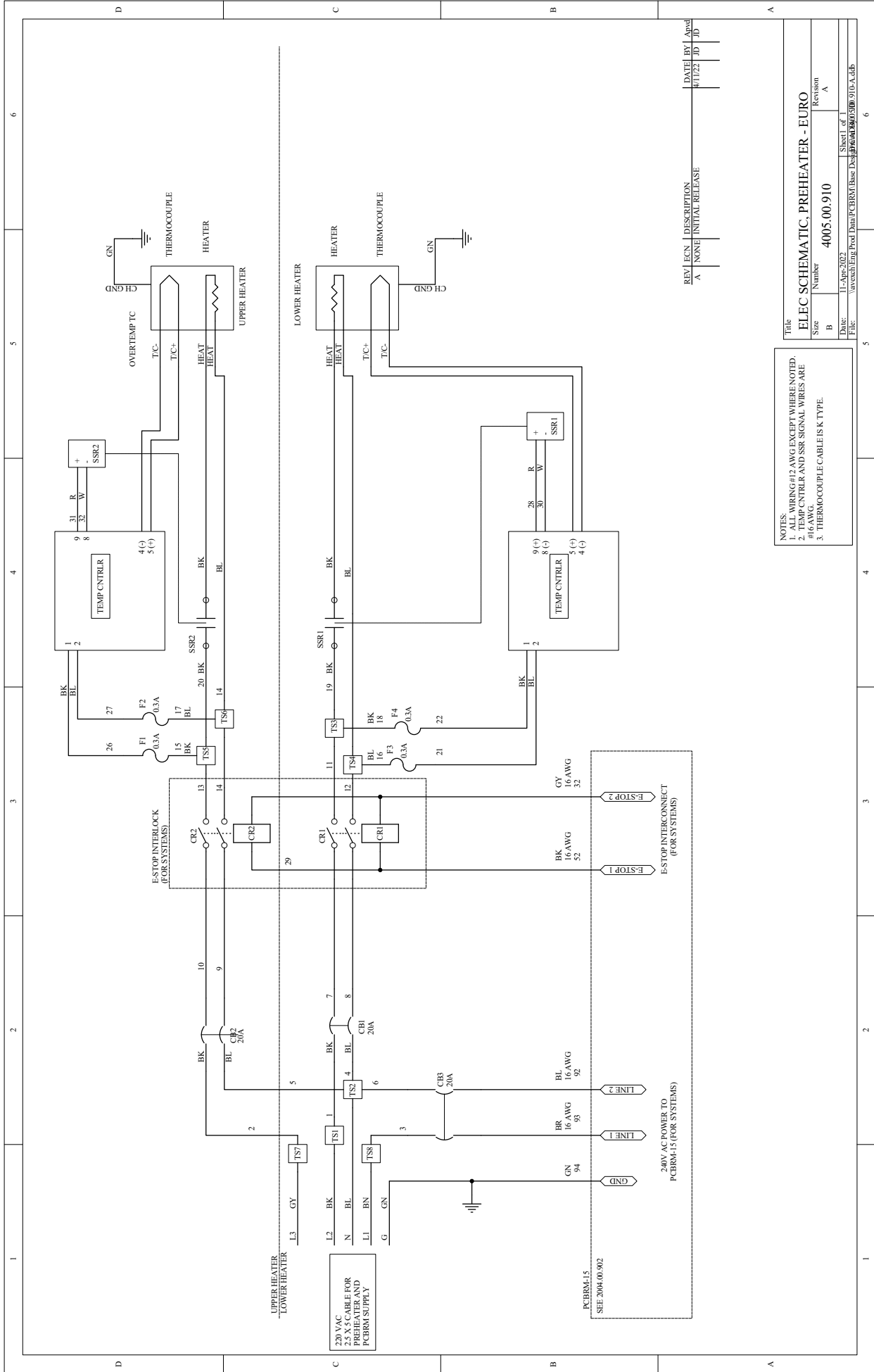

REV/ECN	DESCRIPTION	DATE	BY
A	NONE INITIAL RELEASE	4/1/22	JD

NOTES:
 1. ALL WIRING #12 AWG EXCEPT WHERE NOTED.
 2. TEMP CNTRLR AND SSR SIGNAL WIRES ARE #16 AWG.
 3. THERMOCOUPLE CABLE IS K TYPE.

Title	
ELEC SCHEMATIC, PREHEATER - EURO	
Size	Revision
B	A
Number	4005.00.910
Date	11-Apr-2022
File	\\wccch\Eng Prod Data\PCBRM\Base Design\400500910-A.dwg

rev/date	Description
A7-01-06	Initial build release

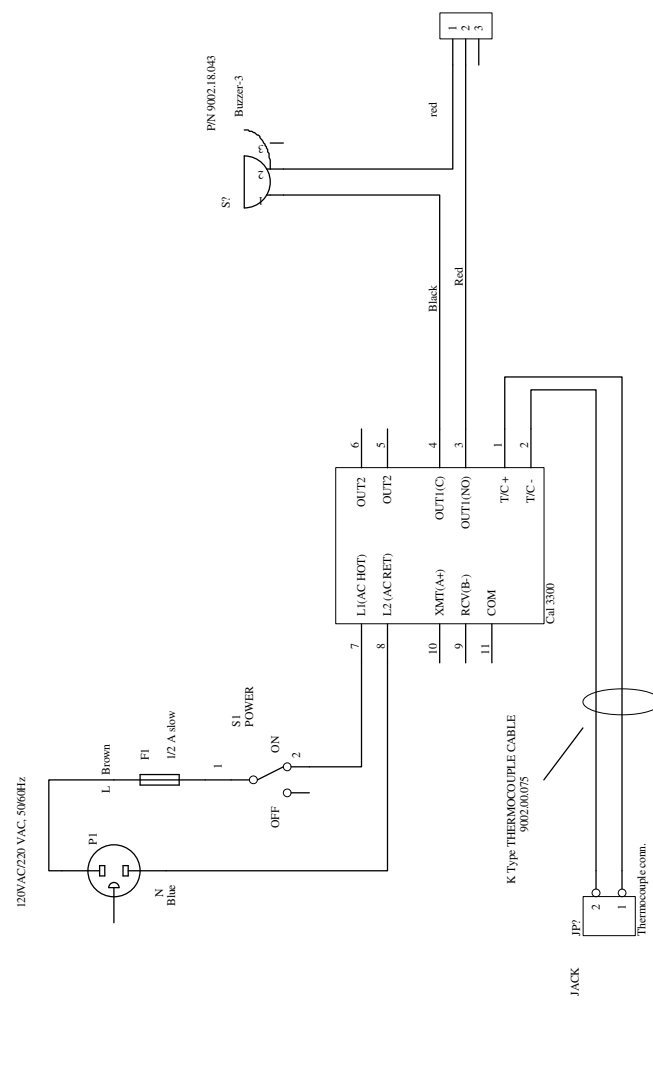

Typical Optional Connections
(only one required, not included)

Shorting Jumper Plug (5003.03.104 Assembly)

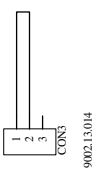

In Preheater position switch (5003.03.101 assembly)

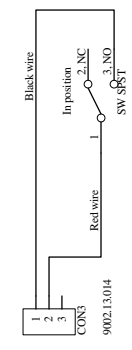

Switch located on the carrier arms

Title		Elect, Schem, Temp Monitor system V	
Size	Number	Revision	
B	5002.03.900	A	
Date:	2-Apr-2014	Sheet of	1
File:	L:\check\left\{schematics\copies\5002.03.900\dwg\MBV:	Sheet of	1
Bernie Andrews		Bernie Andrews	

AIR-VAC Engineering Inc
30 Progress Ave, Seymour CT, 06483
www.air-vac-eng.com

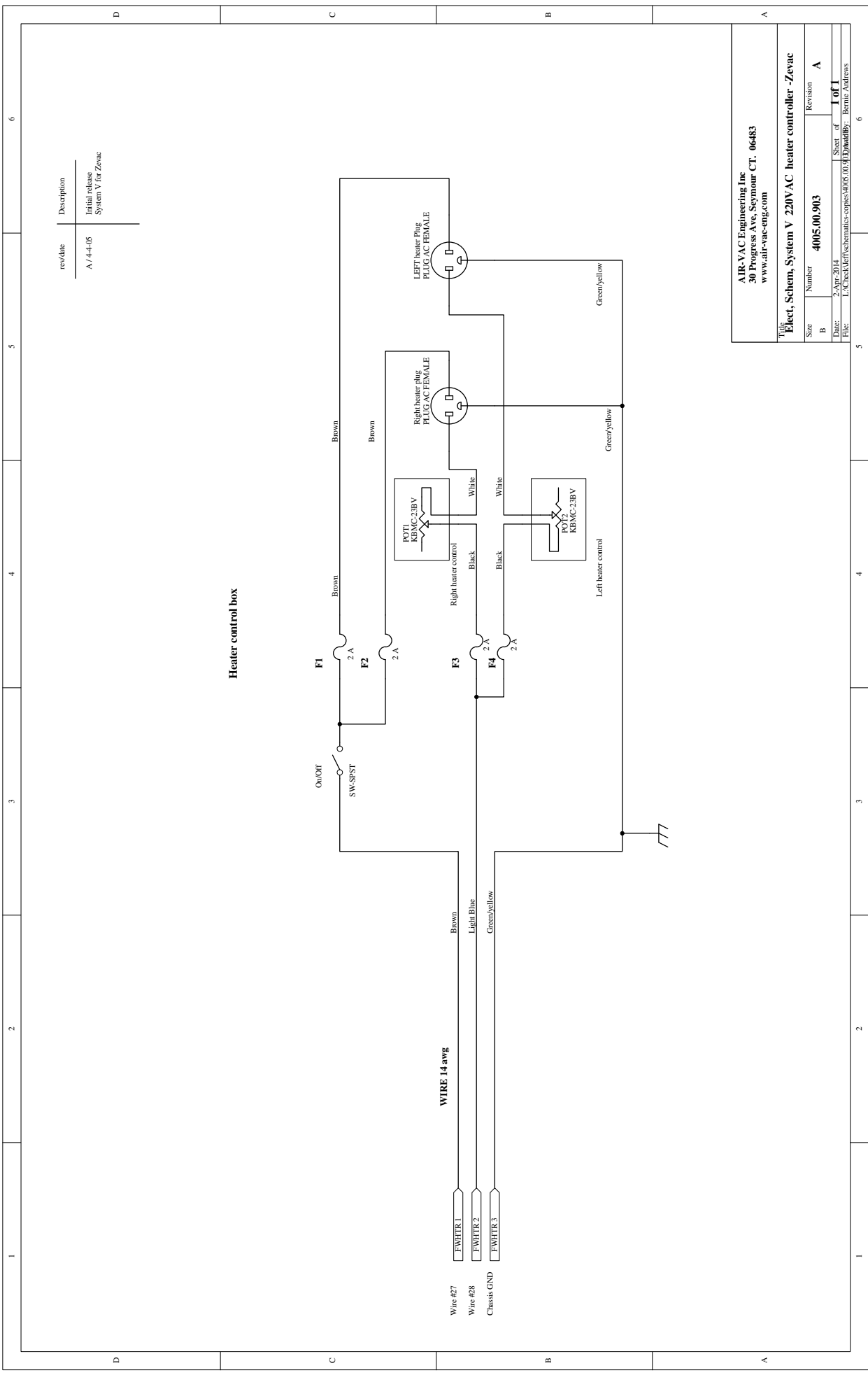

rev/date	Description
A/4-4-05	Initial release System V for Zevac

AIR-VAC Engineering Inc 30 Progress Ave, Seymour CT. 06483 www.air-vac-eng.com	
Title Elect. Schem. System V 220VAC heater controller -Zevac	
Size B	Number 4005.00.903
Date 2-Apr-2014	Revision A
File E:\Check\left\shematics\compas\4005.00.903\Draw\01	Sheet of 1 of 1
6	

CYCLE CONTROLLER ELECTRICAL SCHEMATIC 12818

